

AUSTERITY AND ANTI-SYSTEMIC PROTEST: BRINGING HARDSHIPS BACK IN Statistical Appendices

George W. Pasdirtz

August 2, 2015

<mailto:pasdirtz@wisc.edu>

Multimodel inference is used to develop causal models of anti-systemic austerity protest during the 1990-2000 period in Latin America. Four high-protest, semi-peripheral countries (Argentina, Brazil, Mexico and Venezuela) were chosen for the analysis. Causal models were first developed and tested in Mexico and then cross-validated on Argentina, Brazil and Venezuela. Indexes of IMF pressure, Short-term hardship, Long-term Hardship, Globalization, Civil Liberties and National Social Investment were developed in addition to an index of Austerity Protest. The protest index was developed using careful coding and cross checking of newspaper accounts while the other indexes were largely derived from World Bank Development Indicators and other sources. Indexes were tested for reliability and validity. Causal models for each country were developed and subjected to intensive testing of assumptions. The country-level models (which showed a good deal of historical variability) were then combined and tested using Multimodel averaging. Multimodel path analysis showed significant paths from IMF pressure through short-term hardship to anti-systemic austerity protest. There were also significant effects of shocks to short-term hardship and protest. For two of the countries, Mexico and Venezuela, the path to protest was through long-term hardships generated by the world-system.

(NOTE: Text displayed in red are hyperlinks that allow you to navigate the document.)

Contents

Contents	1
1 Introduction	4
A Theory Explication	4
B Methodology Details	7
B.1 Index Construction	7
B.2 Cross Validation	9
B.3 Statistical Power Analysis	9
B.4 Testing Assumptions	10
B.5 Causal Modeling	10

C	Results of Estimation	12
C.1	Analysis of the Sample	12
C.2	Index Analysis	12
C.3	Country Analysis	14
C.4	Multimodel Estimation	16
C.5	Summary of Results	18
D	Methods Discussion	19
E	Sample Selection	21
E.1	Austerity Protest	21
E.2	High Protest	21
E.3	Country Mnemonics	22
E.4	Power Analysis	22
F	Index Construction	23
F.1	Protest Index (PROT)	23
F.2	IMF Pressure Index (IMFP)	23
F.3	Short-term Hardship Index (STHARD)	24
F.4	Civil Liberties Index (CIVLIB)	24
F.5	Long-term Hardship Index (LTHARD)	25
F.6	National Social Investment Index (NSI)	25
F.7	Economic Index (ECON)	25
F.8	KOF Index of Globalization	26
G	Argentina	27
G.1	Index Construction	27
G.2	Argentina Globalization Index Check	31
G.3	AR: Testing Model Assumptions	32
G.4	AR Granger Causality Testing	33
G.5	AR Path Models	33
H	Brazil	35
H.1	Index Construction	35
H.2	Brazil Globalization Index Check	39
H.3	BR Testing Model Assumptions	40
H.4	BR Granger Causality Testing	41
H.5	BR Path Models	41
I	Mexico	43
I.1	Index Construction	43
I.2	Mexico Globalization Index Check	47
I.3	MX Testing Model Assumptions	48
I.4	MX Granger Causality Testing	49
I.5	MX Path Models	49
J	Venezuela	52
J.1	Index Construction	52
J.2	Venezuela Globalization Index Check	56
J.3	VE Testing Model Assumptions	57
J.4	VE Granger Causality Testing	58
J.5	VE Path Models	58
K	Multimodel Averaging, Estimation and Testing	61
K.1	Overall Multimodel	61

K.2 Argentina + Brazil	62
K.3 Mexico + Venezuela	63
Bibliography	64

1 Introduction

This paper documents index construction and causal modeling for the study of anti-systemic austerity protests in Latin America. First, the theory (Appendix A page 4) and methodology (Appendix B page 7) underlying the study are briefly discussed. Then, an overview of results from the index construction and causal modeling is presented. The detailed results are contained in Appendix F page 23. The conclusions in Section D page 19 suggests that (1) the indexes have adequate (but not perfect) reliability and validity and (2) that the causal models meet all the necessary criteria (normality, lack of autocorrelation and causal ordering) to accept the results of Multimodel testing [9] where models from four high-protest semi-peripheral countries are combined in different ways for overall theoretical tests.

A Theory Explication

For semi-peripheral, open economies in the world-system, a simple model might explain their historical time paths in the late 20th and early 21st centuries: hardship and anti-systemic protest were driven by systemic shocks[40] from the world-system, from their domestic economic systems and from domestic political systems. Shocks might include commodity price shocks (oil, natural resources and agricultural products), financial shocks such as the dot-com bubble, debt crises, or the subprime mortgage crisis and political shocks such as regime changes and revolutions.

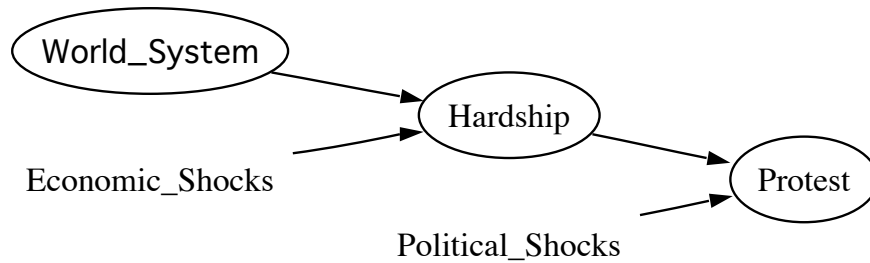

Figure 1: Basic Theoretical Model

The Shock Theory can be captured with the path diagram in Figure 1 page 4. To the simple Shock model, the directed graph adds a causal mechanism: world-system economic conditions create hardship which results in anti-systemic austerity protest, as suggested by Shefner and Stewart[56].

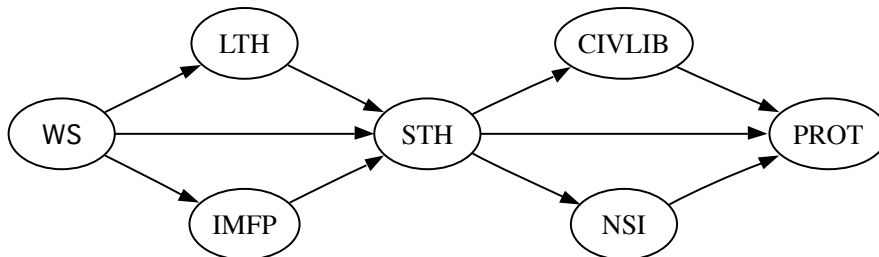

Figure 2: World Systems (WS) Model where LTH=Long-term Hardship, IMFP=IMF Pressure, STH=Short-term Hardship, CIVLIB=Civil Liberties, NSI=National Social Investment, PROT=Protest

The basic model in Figure 1 can be elaborated (ignoring the shocks which will be picked up again in the statistical testing) to include intervening effects[48] suggested by world-systems theory. In Figure 2 on page 4 long-term hardship (LTH) and IMF pressure (IMFP)[68] have been modeled as intervening effects between world-system effects and short-term hardship. Also, changes in civil liberties (CIVLIB) and national social investment (NSI) are modeled as intervening effects between short-term hardship (STH) and anti-systemic austerity protest (PROT). The intervening effects might not be operating in all countries and at all times and the directions of the effects (positive or negative) might not always be as expected.

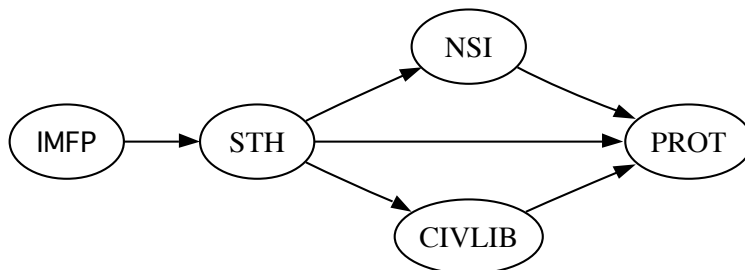

Figure 3: Shefner-Stewart (SS) Model (see Figure 2 for Definitions)

In Shefner and Stewart[56], based on studying Mexico during the late 20th Century, the argument is made that short-term hardship (STH), national social investment (NSI) and changes in civil liberties (CIVLIB) intervene between the effects of IMF pressure (IMFP) and anti-systemic austerity protest (PROT). Increases in national social investment and civil liberties in response to hardship can reduce the need to protest IMF policies. On the other hand, if the IMF austerity measures successfully reduce national social investment and the political system restricts civil liberties, the impetus to protest would be increased. The Shefner-Stewart (SS) model is diagrammed in Figure 3 page 5 where "... the hardships driven by neoliberal policy... energizes democratizing forces that press the state for change"(p. 355)[56].

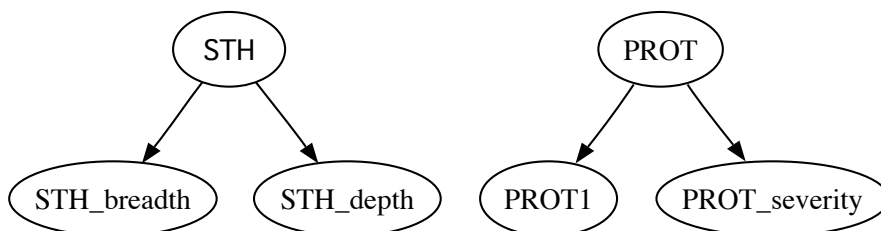

Figure 4: Alternate Index Models (see Figure 2 for Definitions)

Also in Shefner-Stewart[56], there is a suggestion that effects are further mediated by the depth and breadth of short-term hardship and by the level of protest severity. These consideration suggest that the short-term hardship (STH) index and the protest index (PROT) might be further broken down into components as displayed in Figure 4 page 5, an idea that will not only be tested here but also helps to clarify the components of the austerity protest index.

One theoretical issue not addressed by the SS model is the *direction of causation*. In the terminology of General Systems Theory (GST)[64], are the changes in civil liberties and national social investment *feedforward* or *feedback* effects? Shefner and Stewart look at increasing democracy in Latin America as happening coincidentally with Neoliberal free market policies.

... we suggest it is instead the hardships driven by neoliberal policy that energizes democratizing forces to press the state for change. Accordingly, what may appear as a convergence of democratization, neoliberalism and social protest, is actually a causal sequence, beginning with neoliberalism, leading to social protest and ending with democratization. Importantly, as the Mexican transition to political democratization demonstrates, more open politics is not necessarily a cure for longstanding ills of economic inequality[56].

In the Neoliberal model, IMFP, CIVLIB and NSI are exogenous, policy variables manipulated by the state as economic conditions in the world-system (WS) improve *after* the imposition of austerity. In a political systems (PS) model [22, 23, 4], changes in CIVLIB and NSI could either be the direct result of hardship (feedforward) or the result of feedback from protest.

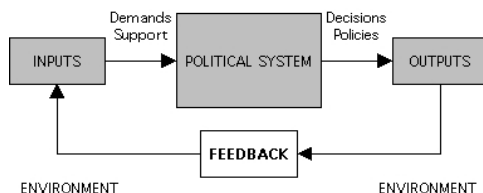

Figure 5: David Easton's Political Systems Model [22, 23, 4]

World-systems theory has successfully applied ideas from Hierarchical Systems Theory[25, 58, 47], specifically that the world-system is coordinated and controlled by the hierarchical relationship between the Core, Semi-peripheral and Peripheral states. There are many other concepts from General Systems Theory[64], Political Systems Theory[22, 23, 4] and Complex Systems Theory[50, 61] that can and will be applied to world-systems analysis in the future. For example, David Easton used the systems model in Figure 5 page 6 to analyze political systems. The feedforward part of Shefner-Stewart could be fit into the input-output framework of Easton's model (the greyed boxes in Figure 5), but since we are not trying to develop a complete theory of the political system (as Easton was trying to do), we do not have to go that far. The feedback part of Easton's model (another form of control), however, will prove useful in developing *alternative testable models*. Anti-systemic protest is a form of feedback about political outputs. A common misinterpretation of Easton [4] is that because there is a feedback loop in the model, the political system will respond. Easton does not assume that the system has to respond and, as the empirical results below will show, unresponsive political systems can either ignore or repress protests, repression being more likely in peripheral countries ([53] page 37). Anti-systemic protests are still feedback, just feedback ignored. These ideas will be further developed and tested below.

Another theoretical issue not addressed by the static path models and existing theory is the dynamic nature of protest. From watching the unfolding of the European Union (EU) Debt Crisis it would appear that protest occurs in response to specific events, at specific points in the business cycle and during long-waves in world-system development[67]. The Subprime Mortgage Crisis was a cyclical event that hit the US economy in 2007 and spread from there to the EU to include Britain, Ireland, Portugal, Italy, Spain and Greece. In 2012, the Greek government passed austerity measures that resulted in street protests and rioting [39]. These austerity protests were events triggered by world-system shocks during a Kondratieff B-phase, a wave of declining economic performance[67].

The static path diagrams presented above do not make secular or cyclical distinctions¹ but the methodology presented next *does* make these distinctions. Existing theories of protest have not addressed the dynamic aspects of protest and it proves to be an unavoidable and important issue

¹For an insightful discussion of the distinction between *secular* and *cyclical*, as the terms are used in world-systems theory, see [67] page 31. World-system definitions should not be confused with *secular components* and *cyclical components* as the terms are used in Principle Components Analysis of time series data.

in the choice of methodology. Although it is possible that there might be secular trends in protests as a result of economic growth and entrenched dysfunctional governments, those cases would seem quite different from shock-driven austerity events and would require different, more complicated dynamic modeling.

B Methodology Details

State-of-the art statistical methodology is based on index construction[30], power analysis[13], generalized cross-validation[28], casual modeling [26, 27, 48] and testing of model assumptions. Each of these topics is discussed below.

B.1 Index Construction

Theoretical concepts of any generality cannot be operationalized by single variables. There is too much meaning in the concepts to be capture by a single indicator[30]. Multiple indicators help define each of the theoretical constructs presented above. Theoretical concepts developed from multiple indicators, however, cannot be assumed to have inherent validity and reliability. Reliability and validity can be thought of in terms of consistency and accuracy, respectively. If we imagine a target at a rifle range, then reliability is the tightness of the shot pattern and validity is how close the shot pattern is to the center of the bull’s eye. For statistical methodologies, there are a number of types of reliability and validity. The ones that are important here involve the percent of variation explained by concept indicators and how well the concept works in statistical models (criterion validity). Concepts that explain more of the variation in the indicators have higher reliability (lower shot dispersion). Concepts that explain more variation in the variables that theory says they should predict have greater criterion validity (closeness to the bull’s eye).

The index construction methodology explained below can distinguish between cyclical and secular trends. Each index has at least two components. The components are ordered by percent of variation explained. For time series data the first component, explaining the most variation, is the *secular* component. The second component, explaining the next largest percent of variation, captures *cyclical* variation over time (for very cyclical phenomenon such as protest, the first component can also be cyclical). If short-term hardship and protest are cyclical events, then the cyclical components should be used in the final modeling.

By partitioning variation into independent secular, cyclical and error components, the error components can be eliminated from the index for statistical analysis.

$$T = S + C + E \tag{1}$$

The Principle Components [36] measurement matrix (presented below for each index) partitions the true score, T into secular, S , cyclical, C , and error, E , components. Each component is, by construction, *independent*. The indexes use S and C which are free of measurement error, E . Error partitioning is an added advantage of using indexes over individual indicators. The individual indicators are not free of measurement error.

It is important to emphasize that the PCA methodology can be applied to a time series of any length and will still typically produce secular and cyclical *components*. The theoretical meaning of the secular and cyclical components will not align well with economic theory unless the time period is specified. For example, Kondratieff Waves play an important part of world-systems theory[67] and are thought to be about 50 years in length [41] consisting of two 25-year phases, the A-phase expansion and the B-phase contraction. PCA components from two 25-year samples (if aligned on the start Kondratieff Wave) would see two secular trends, one increasing and one decreasing, respectively, and would not see the complete Kondratieff Wave. PCA components from 11-years of time series data (the present case) will still typically identify secular and cyclical *components* but will not see Kondratieff Waves. Given the potential for theoretical confusion, it might be better to substitute "oscillatory" for "cyclical" when discussing time series decomposition. However, there is currently no agreed upon usage.

We compute the principal components using the Singular Value Decomposition (SVD). On time series data, the SVD is equivalent to the Spectral Decomposition of $X = \lambda_1 \delta_1 \delta_1' + \lambda_2 \delta_2 \delta_2' + \dots + \lambda_p \delta_p \delta_p' = UDV'$ [36]. The dominant spectral component has the lowest frequency and explains the most variation while the spectral components of higher frequencies have lower variance. An important result from Hierarchical Systems Theory justifies use of the second principal component: "The middle band of frequencies, which remains after we have eliminated the very high and very low frequencies, will determine the observable dynamics of the system under study..." ([57] page 10).

Four Latin American countries were chosen based on their level of protest. High protest countries selected were Argentina, Brazil, Mexico and Venezuela. Moderate and low protest countries were excluded from this analysis (see Appendix E.2 page 21). In Salvatore Babones' categorization scheme[3], Brazil, Mexico, Jamaica and Panama are in the semi-periphery of the world-system (Argentina and Venezuela are not ranked but are likely also in the semi-periphery). No Latin American countries are among the core countries in the world-system using Babones' methodology. Data were taken from the World Development Indicators published by the World Bank [5] and from other sources (see the codebooks in [55] extracted in Appendix F starting on page 23).

Anti-systemic austerity protest measures were developed by searching over 50 national and international English-language newspapers in the LexisNexis General News database[42] to collect events for the current dataset². Longstanding criteria developed by Walton and Ragin[68] were used to define anti-systemic austerity protest as: "(a) mass actions that (b) specifically addressed austerity policies. . . , and (c) stemming from actions by governments that were strongly urged by international institutions (typically the IMF)" ([68] page 882). We reviewed thousands of articles and documented events as austerity protests in the nations of interest for the period of 1990-2000. Additionally, cross-national data on each of the countries was collected from a variety of sources including World Bank and United Nations databases, IMF reports, the Polity IV dataset, Freedom House, and the Wall Street Journal.

Each protest event was coded for the number of cities involved, duration, level of violence, form, and participation. Each coded event supplied information about place, participants, form of protest, and precipitating policy imposed by national governments at the urging of international agencies. In the absence of confirming information, we chose not to code the event making the count very conservative. The absolute level of protest, which is certainly underestimated, is not of primary concern in time series analysis. Rather, the relative changes in protest over time are of primary interest. In a simple regression model, for example $PROT = \alpha + \beta IMFP + E$, the intercept term, α , estimates the base level of protest. The intercept is never estimated in the models presented below and is not needed to test the theory being developed. The models estimated here are unaffected by obvious undercounting of protests as long as the undercounting is relatively (but not absolutely) constant over time. If the undercounting is variable, then the constant has an added error term $PROT = (\alpha + \epsilon) + \beta IMFP + E$. If the random effects error term is not estimated, then it becomes part of the overall error term $PROT = \alpha + \beta IMFP + (E + \epsilon)$ which would work against our hypotheses. In other words, if we find significant results *even with variable undercounting of austerity protests*, the effects are large enough to overcome the added error. The presence of *consistent undercounting* has no effect on the hypothesis while the effect of *variable undercounting* works against the hypothesis but does not *invalidate* it.

From the available data sources, seven indexes were created using Principal Components Analysis (PCA)[36] for the period 1990–2000. The index acronyms were PROT=anti-systemic austerity protest, IMFP=IMF pressure, STHARD=short-term hardship, LTHARD=long-term hardship, CIVLIB=Civil Liberties, NSI=National Social Investment and ECON=Economic Index. The indicators in each index are defined in Appendix F page 23. For each index, at least two components were extracted. Since the underlying data are time series, the first component typically describes

²Lexis-Nexis searches, like other uses of media data, pose problems of "selection and reporting biases" [62]. By using multiple sources on each protest event, however, we were able to triangulate our data in order to gain a more faithful representation of protest events.

the overall *trend* in all the indicators. The second component typically describes the *historically unique* or *cyclical* sources of variation in the indicators. The growth and cyclical indexes are, by definition, independent. The ECON index implements the WS (World System) forces in Figure 1 page 4 and Figure 2 page 4. As described in Appendices G, H, I and J starting on page 27, the second ECON index component (ECON2) captures cyclical process of Globalization (GLOB) in each country.

B.2 Cross Validation

Theory construction and testing are iterative processes[9]. A theoretical model is based not only on speculation and on other theoretical models, but is also based on contact with data and real historical situations. Evidence is accumulated over time for and against the theory. There is no one single test that either proves or disproves a well-articulated theory. One approach to the iterative process is called *generalized cross validation* [28]. Using cross-validation, a theory is developed and tested on a small subset of the available data. Independent subsets or samples of the data are then used to test the theory formally. In the present case, Mexico has been used to develop the theory of hardship and anti-systemic protest presented above[56]. In the present paper, the theory is cross-validated using not only Mexico but also Argentina, Brazil and Venezuela, other semi-peripheral countries in the world-system.

B.3 Statistical Power Analysis

Statistical power analysis can be thought as analogous to the power of a microscope. Assume that a laboratory technician is looking for a microscopic disease agent in a Petri dish. If the power of the microscope is too low, the microscopic agent might be missed. If the power of the microscope is too high, the disease agent might also not be visible when looking at individual molecules. In statistical models, power is determined by sample size and effect size. If you are just looking for very large significant effects, you do not need a larger sample. If you are looking for very small significant differences, you will need a much larger sample. If you are trying to test a theory and discriminate between significant and non-significant effects, a large sample size is actually counterproductive. At some large sample size, all effects are significant. Cohen[13] has helped researchers chose appropriate sample sizes by defining small, medium and large effects for typical statistical measures (means, t-statistics, F-statistics, correlation coefficients, etc.). Cohen's approach will be used to understand what types of effects can be observed given the size of the sample (1990–2000, $n = 11$) available for the present analysis.

The power analysis conducted in Appendix E.4 on page 22 is limited to a univariate correlation coefficient. This means that we will have enough power to test the primary hypothesis which involves the link between STHARD \rightarrow PROT. The power analysis allows for the conclusion that, if this single equation is nonsignificant then there is *no* effect of hardship on anti-systemic austerity protest. Other significant effects in the criterion path model (see Figure 6 page 11 below) can still be accepted as significant findings. What cannot be concluded, given the present sample size, is that non-significant effects in the model are actually zero. Increases in sample size could turn some "marginally significant" results into significant findings (for example, see the IMFP2 \rightarrow STHARD2 coefficient in the BR FF Path model in Section H.5 page 9 where $p = 0.066$, a marginally significant result for an important link). To calculate power against multiple comparisons, a multivariate criterion measure would have to be developed. Morrison[44] presents a number of criterion measures that might be used when it becomes possible to expand the current sample size.

For Multimodel comparisons, the model with the best (lowest) Akaike Information Criterion[1, 9, 10] is chosen. The AIC selects the simplest model among competitors, that is, the best model (smallest residuals) with the fewest path coefficients. For the development of theory, Multimodel inference suggests that models be evaluated not only by accumulated statistical tests but also by the model's richness and simplicity. The best model to explain anti-systemic austerity protest might

be the simple single equation $\text{STHARD} \rightarrow \text{PROT}$ or even $\text{E} \rightarrow \text{PROT}$ (the Shock Model), but the single equation does not have much explanatory richness. The more interesting feedforward equation system $\text{WS} \rightarrow \text{STHARD} \rightarrow \text{PROT}$ provides a richer understanding of anti-systemic protest. Including the feedback equation system $\text{PROT} \rightarrow \text{STHARD} \rightarrow \text{WS}$ in the Multimodel comparison brings in potential insights from Political Systems Theory and further advances our understanding of protest. Including additional intervening variables, as suggested by Shefner-Stewart, would be accepted as long as the added model complexity brings added predictive power (a smaller AIC, that is, smaller residuals corrected for the increase in model parameters).

B.4 Testing Assumptions

Statistical tests are based on assuming a theoretical shape for the population probability distribution. Typically, the Central Limit Theorem is invoked to apply *normal theory* as the population distribution. The Central Limit Theorem [7] proves that adding together indicators, regardless of their basic distributions, will result in a measure which is normally distributed with the classical bell-shaped distribution. The other assumption is independence, typically created by random sampling. In models based on time series data, the independence assumption is often violated by observed *autocorrelation*, that is correlations over time between model residuals. All these assumptions have to be tested before concluding that the normal distribution can be used for hypothesis testing.

B.5 Causal Modeling

From the SS (Shefner-Stewart) and the PS (Political System) models, six causal models [26, 27, 48] were developed: a feedforward (FF) model, a feedback model (FB) and a simplified FF model with two variations for each model. The ability to articulate multiple models allows for Multimodel inference (MMI) [9, 10]. In MMI, the simplest model with the most explanatory power is chosen as the "best" model among a number of competitors. MMI argues that the purpose of science is not only to test hypotheses but also to articulate and develop *models*. Models endure and may even be resistant to "definitive" testing because they contain the *explanation* for what is happening. Statistical tests provide evidence for and against the model but results must accumulate over time. In the present case, all four semi-peripheral Latin American countries have the highest level of anti-systemic austerity protest. The multiple models contain alternative explanations for *why*. Some model might work better in one Latin American country than another. Some other model might work better in core rather than semi-peripheral or peripheral countries. Over time, the evidence accumulates for one model over another. Results from no single country during one single time period can provide a definitive test of the best model.

The feedforward (FF) model is displayed in Figure 6 page 11. In the FF model, globalization, long-term hardship from world-system position and IMF pressure (from a world-system institution) create short-term hardship. IMF Pressure can also directly create protest. Civil liberties and national social investment are intervening effects between short-term hardship and protest. As will become clear from the discussion of index construction below, the second version of the FF model eliminates national social investment which is shown in dashed lines in Figure 6. The feedback (FB) model is displayed in Figure 7 page 11. In the FB model, protest has an immediate effect on short-term hardship and IMF Pressure with NSI and CIVLIB acting as intervening effects. Short-term hardship also has a direct effect on long-term hardship and globalization. The signs of many of the coefficients are expected to be negative or at least result in negative total effects (following all paths from PROT to the dependent variables [31, 38]) to account for *negative feedback*. In the PS model, protest should result in policy changes that reduce the reasons for the protests. In the simplified FF model (Figure 8 page 11), national social investment and civil liberties are modeled as exogenous policy variables that can be increased once austerity policies have had their desired effect.

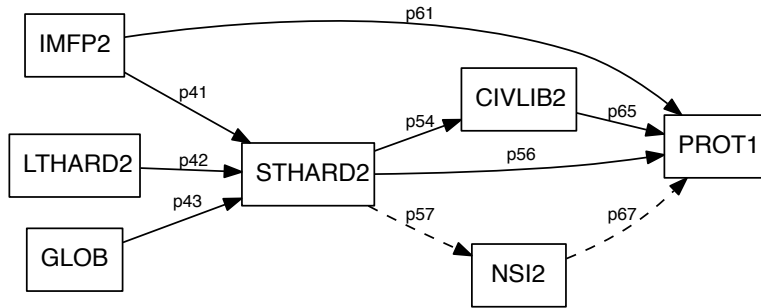

Figure 6: Feedforward Model

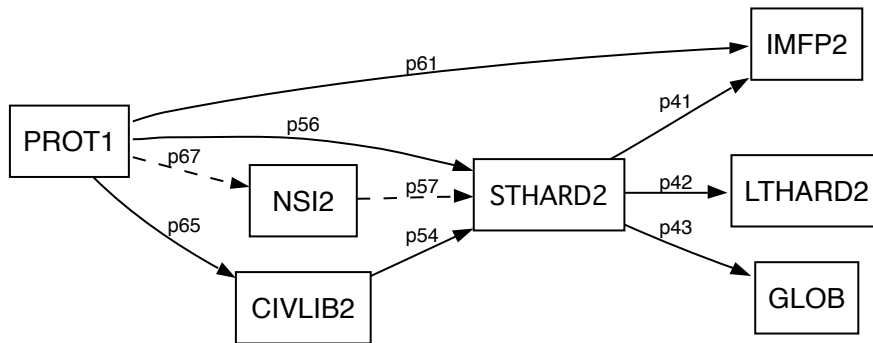

Figure 7: Feedback Model

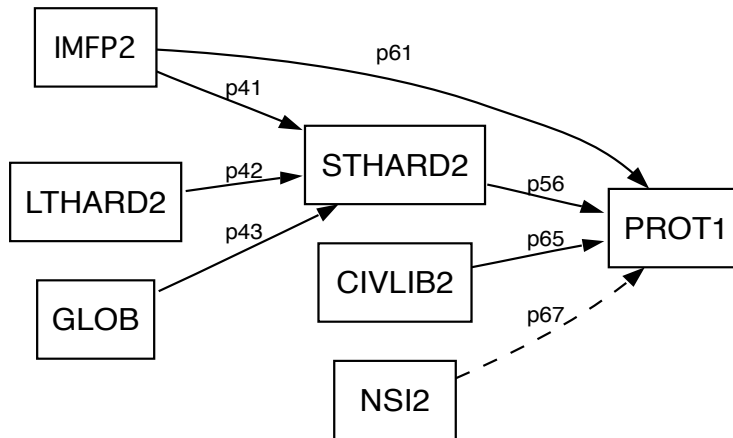

Figure 8: Simplified FF Model

Path diagrams model *instantaneous causality*. Any changes in hardship, for example, should result in immediate increases in the protests. In the real world where data is reported on a yearly basis and effective protests require some time for participants to be mobilized, there will be lags and delays throughout the system. A typical time series model would look at the effect of last year’s PROT, for example, on this year’s protests in addition to the effect of last year’s STHARD. The model might be $PROT_t = \alpha + \beta_1 PROT_{t-1} + \beta_2 STHARD_{t-1} + \epsilon_{t-1}$. A first-order difference equation of this kind is said to test Granger Causality[29]. Lags beyond one period could also be added to such a model. Protests might be more likely in an unresponsive political system that allows grievances to accumulate over many years requiring multiple time lags to model protest. The causal reality for anti-systemic austerity protests probably lies somewhere between the two extremes of instantaneous causes and multi-year, accumulated grievances. The current understanding of causality[48] holds that causes must exist simultaneously or in the prior period to qualify as a valid causal explanation. *Causality-at-a-distance* is seen as a *short-cut* explanation that leaves the mechanism by which effects are transmitted unspecified. Events in the 1970’s and 1980’s may well have caused protest mobilization in the 1990s, but some societal-level mechanism would be needed and that mechanism would require complicated modeling that exceeds our current theoretical understanding. In the modeling below, simultaneous causality and Granger causality will both be tested. Longer lag structures and more complex dynamic causal models will be reserved for future speculations and investigations.

C Results of Estimation

Results are presented for sample selection, index construction, indexes by country, path models by country and an aggregate Multimodel for all the high-protest semi-peripheral Latin American countries. Although the results for the index construction and casual modeling vary across countries, some generalizations can be made taking each index separately across countries.

C.1 Analysis of the Sample

Results for the sample are presented in Appendix E page 21. The data set ran from 1990-2000 ($n = 11$). Protest totals for all Latin American countries are displayed in Figure 12 page 21. There are peaks in the beginning and the middle of the sample period. The protest totals for each Latin American country in the overall sample are given in Appendix E.2 page 21. Brazil, Argentina, Venezuela and Mexico, in that order, have the highest protest totals. Each is a semi-peripheral country in the world-system. A time plot of protest in the high protest semi-peripheral countries is displayed in Figure 13 page 22. Protest in these countries shows a strong peak in 1995.

The power of a statistical test is a joint function of the sample size and the effect size. By choosing a significance level ($\alpha = 0.05$ as the probability of a Type I error, that is, incorrect rejection of a true hypothesis) and desired power ($\beta = 0.80$ the probability of avoiding Type II error, that is, incorrect failure to reject a false null hypothesis) a sample size and effect size can be computed[11]. The results presented in Appendix E.4 page 22 show that large correlations ($r > 0.76$) can be identified with an $n = 11$ (the country-level sample size) and that moderate correlations ($r > 0.41$) can be identified in the high-protest Multimodel ($n = 44$). The sample size has adequate power to test the STHARD \rightarrow PROT link. There is not adequate power to conclude that other non-significant effects might be zero (see Appendix E.4 page 22 for a more complete explanation).

C.2 Index Analysis

The percent of variation explained by each index is a measure of reliability. The indicators that load (have large coefficients) on each index are typically used to interpret the index and the secular or cyclical time path of the index determines how well it might explain either hardship or protest.

For the GLOB index, the items were always weighted to show that increases in the index over time reflected *increasing* globalization as defined by the KOF index.

Protest

The first protest index, PROT1, is in all countries an approximately equal weighting of all the indicators. In all cases, the first index explains at least 80% of the variation in the indicators and thus has high reliability. The second, historically unique index, PROT2, is typically dominated by one of the indicators, either CITIES (Argentina, Brazil), FORM (Mexico), and DURATION (Venezuela). The secondary indexes typically explain another 5% of the variation in the indicators. SEVERITY did not emerge as a separate component in the index construction.

IMF Pressure

The IMF pressure index includes different policy measures used by the IMF to impose austerity and/or create changes in the affected economies. Over time, the policy measures tended not to be used together. For example, the use of the extended fund and the use of IMF credit tended to be separate policy instruments. As a result, no one IMF index explained over 80% of the variation in the indicators. For example, IMF credit dominated the second index in Argentina, but not in other high-protest countries. LNQTA dominated the second index in Brazil; EXFD in Mexico; and DBTEX in Venezuela.

Short-term Hardship

The second short-term hardship index was typically dominated by unemployment and the first index was a relatively equal weighting of the indicators with inflation entering negatively. The first short-term hardship index always explained over 80% of the variation in the indicators and thus had high reliability. A separate STH depth index did not emerge from the analysis of the indicators included.

Long-term Hardship

The second long-term hardship index was dominated by unemployment and family work or children working, except in Venezuela where health expenditure dominated the second index. The first index was a relatively equal weighting of items that were available with some entering negatively. Measures of long-term hardship tended to not be consistently available across countries (zero weightings on an indicator mean that the data was missing).

Civil Liberties

The first civil liberties index did not explain 80% of the variation. The second index tended to be dominated by voting indicators. A priori, a stronger correlation between political development measures and voting might have been expected.

National Social Investment

OBD (Overall Budget Deficit) dominated the second NSI index (Argentina, Brazil, Mexico, and Venezuela). Where data was available, the first index tended to be an equal weighting of the indicators but only tended to explain around 50% of the variation in the indicators. The rationale for including OBD in the index was to capture national social investment funded from debt and to relate this component to IMF pressure to reduced social investment and budget deficits. Our assessment of the NSI index was that it needed further development in a more complex model so it was dropped from the path models.

Economy

The economic index was originally developed to measure environmental sustainability. Impact models [14, 24, 37, 65] formed the basis for the IPCC emission scenarios [45]. Impact models are based on the following identity:

$$C = N \times \frac{Q}{N} \times \frac{E}{Q} \times \frac{C}{E} = N \times q \times e \times c \quad (2)$$

where q is *productivity*, e is *energy intensity* and c is *carbon intensity* and N is population, Q is aggregate economic output, E is energy use and C is carbon emissions. Impact modeling finds that all these variables interact to describe economic growth. The lower-case *intensive* variables describe technologies necessary to create sustainability. Variables for the economic index were chosen based on the findings of Impact models. Impact models provide a better basis for economic growth theory than does the neoclassical economic growth model[2] because, unlike the neoclassical growth model, Impact models are based on the Kaya identity which is true by definition (no similar identity provides the theoretical basis for neoclassical growth theory). In addition to the impact variables, the KOF index of globalization [17, 18, 20, 16, 19] and a indicator of economic freedom from the Heritage Foundation (<http://www.heritage.org/index/>) were also added.

The KOF globalization index includes 23 variables that measure the economic, social and political dimensions of globalization. The theoretical definition of globalization used in the KOF index is "...the process of creating networks among actors at multi-continental distances, mediated through a variety of flows including people, information and ideas, capital and goods.[21]" Since the present analysis contains many other social and economic measures, in Appendix F.8 page 26 globalization is redefined operationally in terms of only economic indicators. In the country analysis, (Appendices G, H, I and J) the reliability and validity tests of the KOF index are presented under the ECON index for each country.

The ECON index construction results indicate that the variables are highly correlated in Latin America. The first index is generally an equal weighting of all the indicators except economic freedom (negative in Argentina). The first index always explained over 80% of the variation in the indicators. The second index tends to be weighted most heavily on unique historical trends involving globalization, economic freedom, energy use, emissions, and business cycles, that is, cyclical or historically unique aspects of globalization. It is the historically unique or cyclical aspects of globalization that we hypothesize creates hardships.³

C.3 Country Analysis

For the country analysis, peaks and troughs in the indexes over time will be identified. These trends need to be considered carefully in terms of causality implied in the Theory Section page 4. In time series estimation algorithms, indexes with secular trend tend to go together while indexes with cycles tend to be related with appropriate lags. The path diagram in Figure 1 page 4 should be kept in mind when reviewing the country results to see if causal patterns emerge that support the model. The definition of the indicator variables for each index is given in Appendix F page 23. Model assumptions were tested with two regression models: (1) $PROT1 = \alpha + \beta_1 IMFP2 + \beta_2 STHARD2$ and $STHARD2 = \alpha + \beta_1 IMFP2 + \beta_2 LTHARD2 + \beta_3 NSI2 + \beta_4 CIVLIB2 + \beta_5 ECON2$. The residuals from these two models were tested both for normality using the Shapiro-Wilk test [54] and for autocorrelation (independence) using the Breusch-Pagan test[8]. Granger causality was tested using the general equation $Q_t = \alpha + \beta_1 Q_{t-1} + \beta_2 X_{t-1}$ where Q is one time series variable and X is one other variable in the data set. Only significant results are reported. Finally, each of the six path models is tested and compared using the Akaike Information Criteria (AIC)[1, 10]. The best model is chosen as the one with the smallest AIC meaning that the model had the smallest

³The GLOB index was not included to address controversies in the world-system literature surrounding whether or not globalization is a unique *new era* in world-system development [66]. Whether unique or not, some political elites in Latin America and the core countries pursued "globalization" and tried to make it work [59, 60]. The GLOB index was meant to control for these initiatives independent of IMF imposed austerity policies.

residuals with the fewest variables, in other words, the simplest model with the best predictive power.

Argentina (Appendix G page 27)

The measurement models and time plots for the AR Indexes can be found in Appendix G page 27. The PROT index shows a very cyclical pattern with no apparent trend over time. The IMFP1 index shows secular change over time while the IMFP2 index peaks in 1995. The STHARD1 index shows growth with an asymptote around 1995. The LTHARD1 index shows secular growth over time while the LTHARD2 index peaks in 1996. The CIVLIB1 index shows acceleration after 1998 while the CIVLIB2 index (voting behavior) shows secular trend. The NSI1 index shows secular trend while the NSI2 index shows a trough in 1996. The ECON1 index shows secular trend while the ECON2 index shows a flat peak (a period of high globalization) between 1991 and 1998. In general the cyclical nature of the PROT index and the secular nature of the STHARD index do not suggest that the two are causally related. The correlation between the KOF index of globalization and the GLOB1 component was $r = 0.92$ suggesting high convergent validity.

Neither the AR Protest model nor the AR Hardship model show either autocorrelation or departures from normality. Granger causality testing identified six significant effects, three on hardship, two on National Social Investment and one on IMFP. The best AR path model was the simplified FF model ($AIC = 19.12$) in which all path coefficients except from IMFP2 \rightarrow PROT1 and from CIVLIB2 \rightarrow PROT1 were significant as were shocks to STHARD1 (E6) and PROT1 (E4). In the Feedback (FB) model there were significant negative effects from PROT1 \rightarrow STHARD2.

Brazil (Appendix H page 35)

The measurement models and time plots for the BR Indexes can be found in Appendix H page 35. PROT1 shows a peak in 1998 and PROT2 shows a peak in 1995. The IMFP1 index shows secular trend while the IMFP2 index shows a trough in 1995 and the IMFP3 index shows a trough a little later between 1995 and 1998. STHARD1 shows secular trend while STHARD2 shows a trough in 1995. LTHARD1 shows secular trend while LTHARD2 begins declining in 1997. CIVLIB1 shows secular trend while CIVLIB2 peaks in 1993, NSI1 shows secular trend while NSI2 shows cycles with two troughs, one in 1991 and another in 1997. The ECON1 index shows secular trend while the ECON2 index (globalization) peaks between 1991 and 1996. The peak in PROT1 in the late 1990's might be caught by these trends. The correlation between the KOF index of globalization and the GLOB1 component was $r = 0.95$ suggesting high convergent validity.

Neither the BR Protest model nor the BR Hardship model show either autocorrelation or departures from normality. Granger causality testing identified six significant effects, three on short-term hardship, one on IMF pressure, one on civil liberties and one on globalization (ECON2). The best BR path model was the simplified FF model ($AIC = 24.27$) with all effects in the model significant at the $p < 0.05$ level except IMFP2 \rightarrow STHARD2, ECON2 \rightarrow STHARD2, and CIVLIB2 \rightarrow PROT1. All the shocks were significant. In the FF model there were significant negative effects from CIVLIB2 \rightarrow STHARD2 and PROT1 \rightarrow IMFP2.

Mexico (Appendix I page 43)

PROT1 peaks in 1995 while PROT2 has both peaks and trend acceleration after 1998. The IMFP1 index shows secular decline while IMFP2 shows a peak between 1995 and 1996 while IMFP3 shows a peak in 1994. The STHARD1 index shows a takeoff after 1995 while the STHARD2 index peaks in 1995. The LTHARD1 index shows secular trend while the LTHARD2 index peaks in 1995. The CIVLIB1 index shows secular trend while the CIVLIB2 index shows a peak in 1994 and a trough in 1998. The NSI1 index shows secular decline (this index could be re-weighted to show secular increases since it is dominated negatively by HEP and PED). The NSI2 (OBD) index shows a peak in 1992. The ECON1 index shows secular trend while the ECON2 index peaks in 1995.

The indexes that peak in 1995 (PROT1, STHARD2 and ECON2) suggest a causal relationship. The correlation between the KOF index of globalization and the GLOB1 component was $r = 0.94$ suggesting high convergent validity.

Neither the MX Protest model nor the MX Hardship model showed either significant autocorrelation or departures from normality. Granger causality testing identified five significant effects, the only one that did not involve the exogenous variables of the MX path models was IMFP2 \rightarrow PROT2. The simplified FF model ($AIC = 25.50$) showed all effects in the model significant except IMFP2 \rightarrow STHARD2 and LTHARD2 \rightarrow STHARD2. Notice also the IMFP2 \rightarrow STHARD2 was not significant but that the Granger causal relationship was significant suggesting that a dynamic model might fit this relationship better. In the FB model there no significant negative effects.

Since Mexico was the country in which our model was developed (to be cross-validated on other countries) the failure to find a significant effect from STHARD2 \rightarrow PROT1 led to the substitution of LTHARD2 for STHARD2 in the modified FF model (Figure 38 page 51). In the modified model, all effects were significant except IMFP2 \rightarrow LTHARD2, and GLOB \rightarrow LTHARD2.

Venezuela (Appendix J page 52)

PROT1 shows two peaks, one in 1992 and another in 1996 while PROT2 shows multiple peaks in 1991, 1993, 1996 and possibly 1998 before declining. IMFP1 shows a peak in 1992, IMFP2 shows a trough in 1992 and a mild peak in 1995 while IMFP3 shows peaks in 1993 and 1997-1998. STHARD1 shows a trough in 1992 and secular increase after that. STHARD2 shows a trough in 1993 and a peak in 1996. LTHARD1 shows secular trend while LTHARD2 has a peak in 1992, a trough in 1996 and another peak between 1997-1998. The CIVLIB1 shows secular decline while the CIVLIB2 index (voting) shows a peak between 1996 and 1998. The NSI1 index shows secular trend with a peak in 1996. The NSI2 index shows cyclical behavior with a peak in 1996. The ECON1 index shows secular increase while the ECON2 index (globalization) shows peaks in 1992 and 1997. The correlation between the KOF index of globalization and the GLOB1 component was $r = 0.95$ suggesting high convergent validity.

Neither the VE Protest model nor the VE Hardship model showed either significant autocorrelation or departures from normality. Granger Causality testing identified seven significant effects. Among the endogenous variables there was one significant effect from PROT1 \rightarrow LTHARD2. The the simplified FF model ($AIC = 35.01$) showed all significant except for IMFP2 \rightarrow STHARD2, ECON2 \rightarrow STHARD2 and STHARD2 \rightarrow PROT1. All shocks to the the endogenous variables PROT1 and STHARD2 were significant. In the FB model there were only significant negative effects from STHARD2 \rightarrow LTHARD2. The failure to find a significant link between STHARD2 \rightarrow PROT1 led to estimation of a modified FF model where LTHARD2 was substituted for STHARD2 (Figure 47 page 60). In the modified FF model, all effects are significant except for IMFP2 \rightarrow LTHARD2 and GLOB \rightarrow LTHARD2.

C.4 Multimodel Estimation

The country analysis presented above shows a great deal of diversity among significant effects within the models. The way effects are transmitted from world-system variables to anti-systemic austerity protest show many differences. The generality of the SS model can be tested through Multimodel inference[10] by averaging the correlation coefficients for the best country models and then conducting an overall test. The results of the MM test are presented in Appendix K on page 61.

The simplified FF path model performs acceptably ($AIC = 33.12$). All effects in the model are not significant at the $p \leq 0.05$ except for IMFP2 \rightarrow STHARD2 \rightarrow PROT1 and the effect of shocks. The simplified Multimodel path diagram is presented in Figure 9 on page 17 (the path diagram is repeated in the appendix Figure 48 page 62). The major path of transmission through the model (the total effects) are from IMF pressure through short-term hardship to anti-systemic austerity protest and from shocks to short-term hardship and directly to protest. The model confirms the important of short-term hardship as an intervening variable.

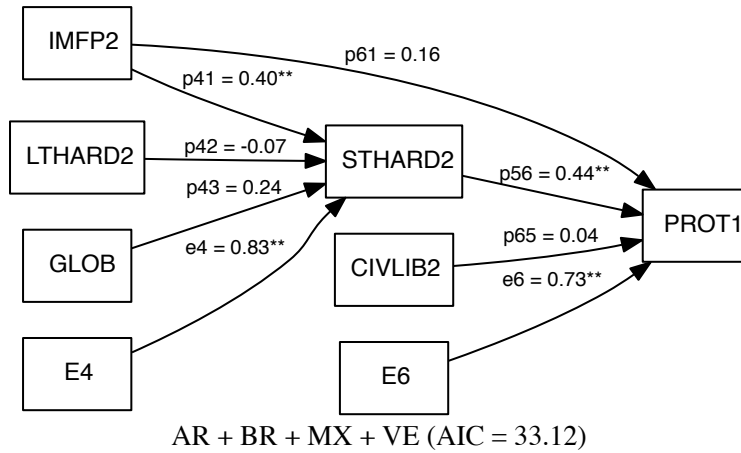

Figure 9: Best MultiModel (* = $p \leq 0.05$, ** = $p \leq 0.01$)

The country-level analysis also suggests that AR and BR might be more similar to each other than to MX and VE. To explore these potential similarities, two further Multimodels were constructed based on 22 observations in each. The major difference between these Multimodels is the role played by Long-term Hardship transmitted from the world-system. The Multimodel for

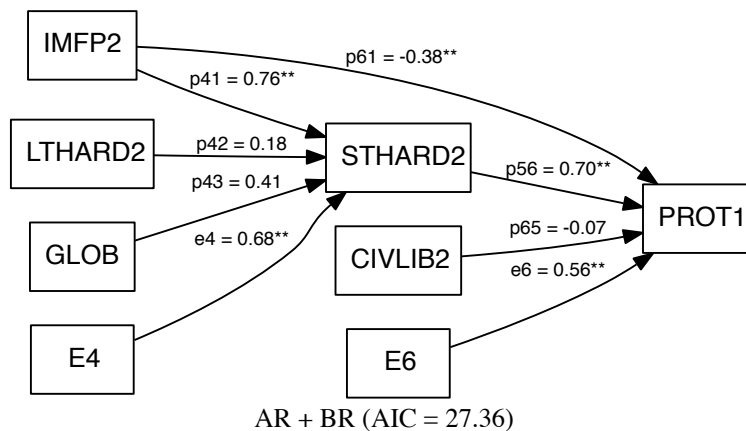

Figure 10: Best Multi Model, Argentina and Brazil (* = $p \leq 0.05$, ** = $p \leq 0.01$)

Argentina and Brazil (Figure 10 on page 17) is similar to the overall Multimodel (Figure 9 on page 17) in that the IMFP2 -> STHARD2 -> PROT1 path is still significant, but now there is

also a path from IMFP2 \rightarrow PROT1. The ($AIC = 27.36$) is somewhat better than the overall multimodel.

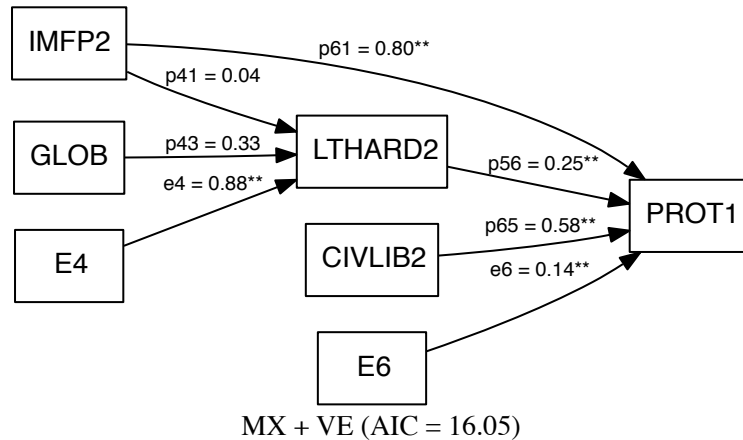

Figure 11: Best Multi Model, Mexico and Venezuela ($* = p \leq 0.05, ** = p \leq 0.01$)

The best Multimodel for Mexico and Venezuela (Figure 11 on page 18) differs from the previous Multimodels in that Long-term Hardship, IMF Pressure and Civil Liberties now have a direct and significant effect on Anti-systemic Austerity Protest. The ($AIC = 16.05$) is better than the modified multimodel for Argentina and Brazil.

C.5 Summary of Results

The results can be summarized by model and by the variables used in each model.

Summary of Results by Model

Looking across the models, the following pattern of results emerged:

- The simplified Feed Forward (FF) model (Figure 8 page 11) was always the best model, that is, the model with the smallest AIC. For Mexico and Venezuela, the best FF model involved substituting long-term for short-term hardship.
- The Feedback (FB) model was not a strong competitor in any of the semi-peripheral Latin American countries.

Summary of Results by Variable

Looking across the variables used in the path models, the following pattern of results emerged:

- IMF Pressure was applied unevenly across the countries during the 1990-2000 period and had uneven effects on protest and hardship.
- Some form of hardship, either long-term or short-term, always led to protest.
- Globalization had uneven effects across the countries.

- Granting of civil liberties had uneven effects on protest across the countries.
- Shocks always had a significant effect on hardship (E4) and protest (E6).

D Methods Discussion

Anti-systemic austerity protest is inherently a cyclical, historically unique phenomenon. Neoliberal ideology views austerity measures as shocks meant to return a dysfunctional economic system to a sustained, exponential growth path. The austerity measures are meant to impose short-term hardship and they do. The resulting anti-systemic protests (if any) are seen by Neoliberals as a short-term nuisance to be endured until the economy is growing again. Political Systems Theory views anti-systemic protest as a strong negative feedback effect. If the political system does not respond by increasing civil liberties or increasing national social investment, the political system will be in danger of losing legitimacy. Any increases in national social investment, however, are discouraged by Neoliberal ideology since it is precisely these investments that are thought to be restricting economic growth. Increases in civil liberties (democracy) are thought to result from increases in economic freedom as an outcome of free-market austerity measures rather than the result of rights won through political struggle. This is a complex dynamic to be explained with a causal model. The mix of policy measures and political feedbacks need not play out in a law-like, preordained fashion. Policy measures may or may not be effective. Protests may or may not be met by a political response. The political response may or may not reduce the adverse effects of austerity. The political response can be an attempt to repress the protests. To increase the historical complexity, the cyclical policy measures are also being imposed on a secular pattern of economic growth and hardship.

The Shefner-Stewart (SS) model explains protest through a number of intervening measures to include short-term hardship. SS theory is essentially a feed forward (FF) model that does not make an overt distinction between secular increases in protest and cyclical outbreaks of protest. The distinction between secular and cyclical had to be introduced through the methodology of Principal Components index construction on time series data. There are some secular trends in hardship within the sample but protest indexes are mainly cyclical. It may be that variations in the secular trends explain cyclical outbreaks of protest, but this dynamic would be difficult to model using path analysis. Hardship is another matter. There are secular trends in hardship (both short- and long-term) in each of the semi-peripheral Latin American countries presented in Appendices G, H, I and J starting on page 27. The secular trends could effectively be modeled as a result of secular trends in the world-system in a study that was focused solely on hardship.

The failure of protest severity and short-term hardship depth to emerge as separate indicators suggests either that (1) new indicators are needed for these concepts or (2) a larger sample size will be needed to identify subindexes. To break out protest severity as a separate indicator in the present analysis would be to introduce multi-collinearity and measurement error. The STH index could also be expanded to include measures of subsistence to operationalize the Moral Economy literature [52, 63]. There may still be measurement problems with some of the intervening variable indexes and there will be analytical challenges establishing the link between indexes and anti-systemic austerity protest.

In spite of some open theoretical and measurement issues and in spite of the clear diversity in country-level responses to world-system shocks and cycles, Multimodel inference showed a clear path from short-term world-system cycles through short-term hardship to anti-systemic austerity protest, confirming the fundamental insight of the Shefner-Stewart model. The absence of strong feedback effects suggests, not surprisingly, that political systems in Latin America are not very responsive. Whether political systems anywhere are very responsive to anti-systemic protests is an important question for future research. Another important question for future research is the secular growth of hardship in semi-peripheral and peripheral countries. These effects are predicted by world-systems theory and are quite visible in the present sample. The sample needs to be further expanded to include all of the late 20th century. Expanding the sample of anti-systemic austerity

protests will be more difficult because of the care and effort that has to be involved coding protest events from newspaper sources. That project, however, can usefully be continued moving back into the 1970's and 1980's in Latin America and forward to the current anti-systemic austerity protests that result from the 2007-2008 world-wide financial crisis.

E Sample Selection

Anti-systemic austerity protests were coded from the LexisNexis database for 19 Latin American Countries (see Appendix E.2 page 21). Countries were selected for the high protest analysis to maximize variation in protest. Countries were divided into three groups: high, medium and low protest. Data collection covered the period from 1990 - 2000. Data were taken from the World Development Indicators published by the World Bank [5] and from other sources (see the codebooks in [55]).

E.1 Austerity Protest

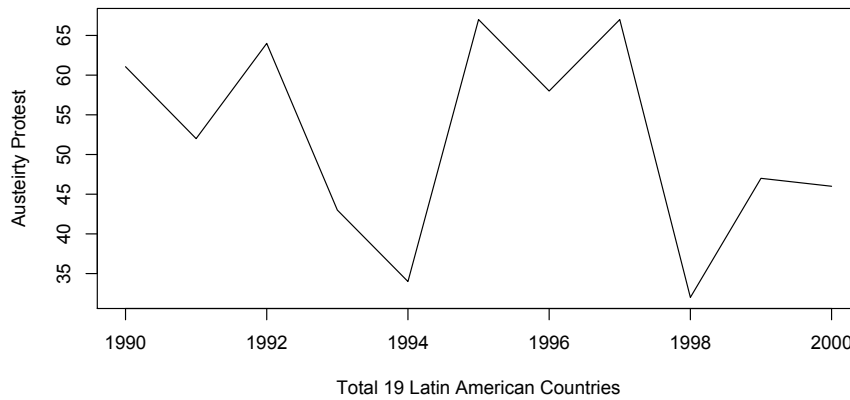

Figure 12: Protest Totals Over Time

E.2 High Protest

For the period 1990-2000, all anti-systemic austerity protests were totaled for each country. The four highest totaled countries were chosen for the high protest group.

Cuba	Jamaica	Honduras	Costa Rica
0	2	4	5
Panama	Uruguay	Guatemala	El Salvador
5	7	9	10
Dominican Republic	Haiti	Nicaragua	Chile
20	24	29	32
Peru	Bolivia	Ecuador	Mexico
35	37	48	59
Venezuela	Argentina	Brazil	
60	86	96	

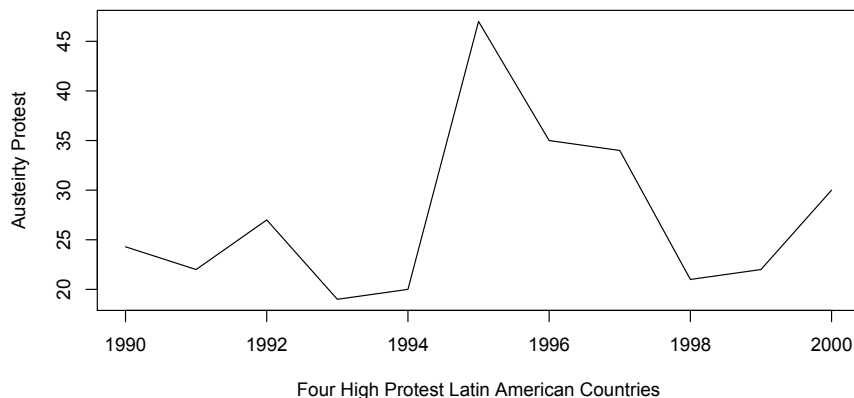

Figure 13: High Protest Totals over Time

E.3 Country Mnemonics

The following two-digit mnemonics were used for each of the high austerity protest countries.

AR Argentina

BR Brazil

MX Mexico

VE Venezuela

E.4 Power Analysis

All statistical analyses were based on standardized scores and correlation coefficients. For a sample size with 11 observations (the individual country data from 1990-2000) the approximate power using the arctangh transformation in the R package `pwr`[11] is:

```
n = 11
r = 0.755788
sig.level = 0.05
power = 0.8
alternative = two.sided
```

For the Multimodel comparisons (four countries) where the number of observations is 44, the approximate power using the arctangh transformation in the R package `pwr` is:

```
n = 44
r = 0.4108969
sig.level = 0.05
power = 0.8
alternative = two.sided
```

The power analysis suggests that, using Cohen's terminology[13], only large effects can be identified in the country-by-country analysis while medium effects can be identified in the Multimodel analysis. To have adequate power to detect moderate effects in each country, the sample size would

have to be increased (a future data collection project has already been started). To re-emphasize what was stated in Section B.3 on page 9 above, there is enough power to cover a single univariate statistical test of the primary hypothesis, HARD \rightarrow PROT. Other links in the model found to be significant can still be accepted. What cannot be concluded, except if HARD \rightarrow PROT is non-significant, is that other effects in the model are zero. Some marginally significant results could become significant with a large sample size (for example, see the IMFP2 \rightarrow STHARD2 coefficient in the BR FF Path model in Section H.5 page 9 where $p = 0.066$, a marginally significant result for an important link). It can only be concluded that no support was found for the insignificant path model coefficients given the current sample size. For Multimodel comparisons, we simply choose the model with the best (lowest) Akaike Information Criterion[1, 9, 10]. The AIC selects the simplest model among competitors, that is, the best model (smallest residuals) with the fewest path coefficients.

F Index Construction

Six indexes were constructed using Principal Components Analysis (PCA). The indexes were PROT = anti-systemic austerity protest, IMFP=IMF pressure, STHARD = short-term hardship, LTHARD = long-term hardship , CIVLIB = civil liberties, NSI = national social investment and ECON = economic index. The printouts below present the measurement matrix and the fraction of variance explained by each index. The measurement matrix contains the weights assigned to each indicator in the index construction. In general, indexes have been weighted such that the largest weight for each index enters with a positive sign. Assigning a positive sign to the highest weighted indicator allows the index time path to be described as being driven by that indicator. For the globalization index (ECON2 or GLOB), the signs of the weights were chosen such that the weight attached to the KOF index of globalization was always positive. The indexes were constructed from the indicators listed in the next section. Missing data was non-linearly interpolated using spline smoothing available in the base R package[51]. Unlike linear interpolation, non-linear spline smoothing does not bias the change scores from year to year but it does reduce the variation (as does linear interpolation). In cases where non-linear spline interpolation did not produce reasonable results (typically when missing data appear at the beginning of a series), the EM algorithm was used[15]. Where data for an entire indicator is missing, the weights in the measurement matrix are zero.

F.1 Protest Index (PROT)

Anti-systemic austerity protests were coded using the LexisNexis General News database[42].

FREQ Frequency of protest

CITIES Cities involved in protest

DURATION Duration of protest

SEVERITY Severity of protest

FORM Form of protest

PARTIC Participation in protest

F.2 IMF Pressure Index (IMFP)

The IMF Pressure index was based on Walton and Ragin[68].

INDETLVL World Bank Indebtedness Level [5]

STBDT Short-term debt % of external debt [5]

EXDTO External debt, total (DOD, current US\$) [5]

LNQTA Loans/IMF Quota (ratio of loans to IMF quota) [35]

EXFD Use of Extended Fund (Stand-by and Extended Arrangements Drawn)[34]

RENEGOF Official Debt Restructurings[6]

RENEGCM Commercial Debt Restructurings[6]

DBTEX Debt Service to Exports (ratio of debt service to total exports)[6]

IMFCR Use of IMF credit (DOD, current US\$)[5]

F.3 Short-term Hardship Index (STHARD)

INFLA Inflation (% annual change to consumer prices) [5]

HPIVAL Human Poverty Index, Values [46]

HPI1RK Human Poverty index, Rank [46]

PVLN8994 Population below income poverty line 9%) \$ 1 a day (1985 PPP\$) [46]

CPI Consumer Price Index (1995=100) [5]

HCE Household Final Consumption (constant 1995 US\$) [5]

UNEM Unemployment, total (% of total labor force) [5]

fpi90 Food Price Index [5]

F.4 Civil Liberties Index (CIVLIB)

DEMOC Institutionalized Democracy Scores [43]

AUTOC Institutionalized Autocracy Scores [43]

COMP Competitiveness of Participation [43]

plcomp90 Concept: Political Competition [43]

PR Political Rights (Freedom House) [32]

CL Civil Liberties (Freedom House) [32]

FS Freedom Score (Freedom House) [32]

wrnkvt World Rank in Voter Turnout [33]

numelect Number of Elections since 1945 [33]

avgvotur Average Voter Turnout (Number of Votes/Voting Age Population) [33]

F.5 Long-term Hardship Index (LTHARD)

SL.UEM.TOTL.ZS Unemployment, total (% of total labor force) [5]

MRI Mortality Rate, infant (per 1,000 live births) [5]

CIFPINEQ CIFP index, Gini Coefficient of inequality (income and expenditure) [12]

LEB Life Expectancy at birth, total years [5]

ACSW9097 Population without access to safe water (%) [46]

ACSN9097 Population without access to sanitation (%) [46]

HEP Health Expenditure, public (% GDP) [5]

SL.UEM.LTRM.ZS Long-term unemployment (% of total unemployment) [5]

SL.FAM.WORK.ZS Contributing family workers, total (% of total employed) [5]

SL.TLF.0714.ZS Economically active children, total (% of children ages 7-14) [5]

SL.TLF.PART.ZS Part time employment, total (% of total employment) [5]

F.6 National Social Investment Index (NSI)

OBD Overall budget deficit, including grants (% of GDP) [5]

HEP Health expenditure, public (% of GDP) [5]

PED Public Education Expenditure [5]

CGDT Central government debt, total (% of GDP) [5]

GRGDP Government Revenue/ GDP 1975 (Govt Rev % of GDP, WDI) [5]

F.7 Economic Index (ECON)

Economic data were taken from the World Development Indicators[5].

EN.ATM.CO2E.KT CO2 emissions (kt)

NY.GDP.MKTP.KD GDP (constant 2000 US\$)

EG.USE.COMM.KT.OE Energy use (kt of oil equivalent)

SL.TLF.TOTL.IN Labor force, total

SP.POP.TOTL Population, total

INDEF Index of Economic Freedom

KOF KOF index of globalization <http://globalization.kof.ethz.ch/>

F.8 KOF Index of Globalization

To test the reliability and validity of the KOF index of globalization[21], the following measures were used to describe only the economic dimension of globalization. The economic dimension focuses on foreign trade activity and the level of trade restrictions. All data were taken from the World Development Indicators[5].

- TX.VAL.SERV.CD.WT** Commercial service exports (current US\$)
- TM.VAL.SERV.CD.WT** Commercial service imports (current US\$)
- IS.SHP.GOOD.TU** Container port traffic (TEU: 20 foot equivalent units)
- IC.EXP.COST.CD** Cost to export (US\$ per container)
- IC.IMP.COST.CD** Cost to import (US\$ per container)
- GC.TAX.IMPT.CN** Customs and other import duties (current LCU)
- BN.CAB.XOKA.CD** Current account balance (BoP, current US\$)
- DT.TDS.DPNG.CD** Debt service on external debt, private nonguaranteed (PNG) (TDS, current US\$)
- EG.IMP.CONNS.ZS** Energy imports, net (% of energy use)
- TX.VAL.MRCH.XD.WD** Export volume index (2000 = 100)
- NE.RSB.GNFS.CD** External balance on goods and services (current US\$)
- BX.KLT.DINV.CD.WD** Foreign direct investment, net inflows (BoP, current US\$)
- PA.NUS.FCRF** Official exchange rate (LCU per US\$, period average)
- IQ.WEF.PORT.XQ** Quality of port infrastructure, WEF (1=extremely underdeveloped to 7=well developed and efficient by international standards)
- TM.TAX.MRCH.SM.AR.ZS** Tariff rate, applied, simple mean, all products (%)
- GC.TAX.INTT.RV.ZS** Taxes on international trade (% of revenue)

G Argentina

G.1 Index Construction

Argentina Protest

Output Measurement Model

Measurement Matrix

	FREQ	CITIES	DURATION	SEVERITY	FORM	PARTIC
[1,]	0.41628	0.3914	0.4116	0.4048	0.4076	0.4173
[2,]	0.07666	0.7751	0.1997	-0.3813	-0.3640	-0.2750

Fraction of Variance

[1]	0.9180	0.9576	0.9764	0.9889	0.9982	1.0000
-----	--------	--------	--------	--------	--------	--------

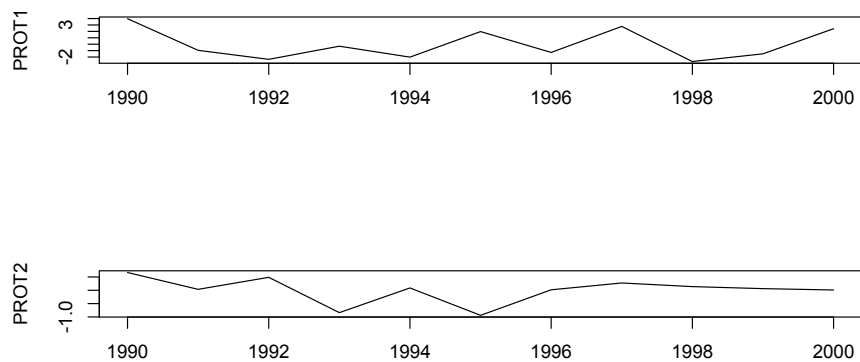

Figure 14: Argentina Protest Index

Argentina IMF Pressure Index

Output Measurement Model

Measurement Matrix

	IMFCR	LNQTA	EXFD	DBTEX	EXDTO	STDBT	INDETLVL	RENEGCM	RENEGOF
[1,]	0.081380	-0.4711	-0.3738	0.52441	0.4806	0.3546	0	0	0
[2,]	0.765858	0.3029	0.4306	0.05679	0.3366	0.1405	0	0	0
[3,]	-0.001745	0.2965	-0.2788	-0.31128	-0.2020	0.8346	0	0	0

Fraction of Variance

[1]	0.5563	0.8168	0.9367	0.9895	0.9983	1.0000	1.0000	1.0000	1.0000
-----	--------	--------	--------	--------	--------	--------	--------	--------	--------

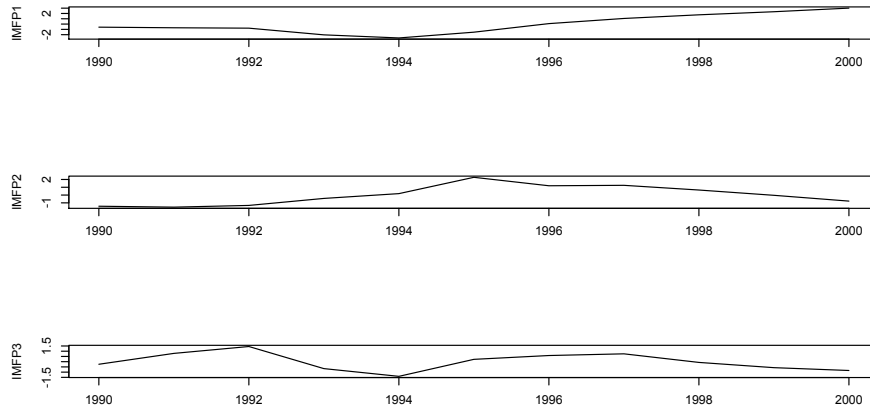

Figure 15: Argentina IMF Pressure Index

Argentina Short-term Hardship Index

Output Measurement Model

Measurement Matrix

	UNEM	HPI1RK	HPIVAL	PVLN8994	PVLNNATI	HCE	CPI	INFLA
[1,]	0.3861	1.110e-16	0	0.000e+00	0	0.45785	0.4591	-0.47732
[2,]	0.7986	-3.886e-16	0	-1.388e-17	0	0.08137	-0.3834	-0.07024

fpi90

[1,]	0.4502
[2,]	-0.4512

Fraction of Variance

[1]	0.8694	0.9757	0.9980	0.9995	1.0000	1.0000	1.0000	1.0000	1.0000
-----	--------	--------	--------	--------	--------	--------	--------	--------	--------

Argentina Long-term Hardship

Output Measurement Model

Measurement Matrix

	HEP	ACSW9097	ACSN9097	CIFPINEQ	MRI	LEB	SL.UEM.LTRM.ZS
[1,]	0.329	1.110e-16	0.000e+00	0	-0.45550	0.4607	0
[2,]	-0.350	8.327e-17	1.110e-16	0	0.03434	-0.1256	0

	SL.UEM.TOTL.ZS	SL.FAM.WORK.ZS	SL.TLF.0714.ZS	SL.TLF.PART.ZS
[1,]	0.1813	0.2330	0.421573	0.4551
[2,]	0.6923	0.5967	-0.008504	-0.1589

Fraction of Variance

[1]	0.6339	0.8549	0.9318	0.9853	0.9963	0.9999	1.0000	1.0000	1.0000	1.0000
[11]	1.0000									

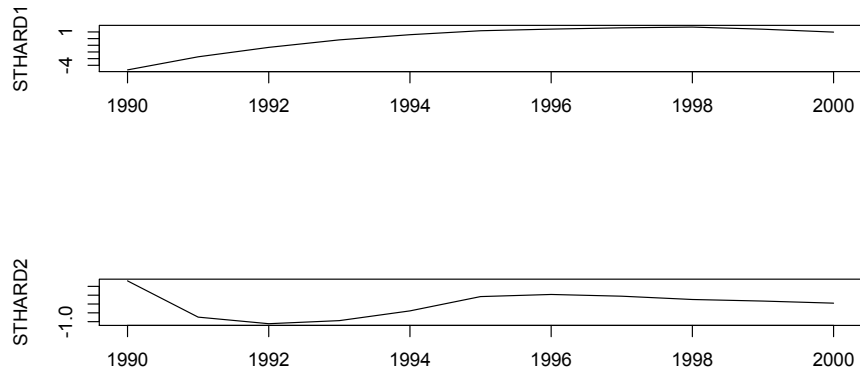

Figure 16: Argentina Short-term hardship Index

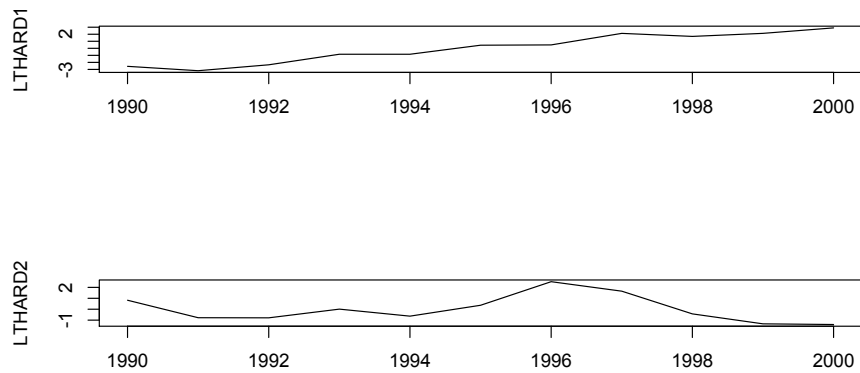

Figure 17: Argentina Long-term Hardship Index

Argentina Civil Liberties Index

Output Measurement Model

Measurement Matrix

	DEMOC	AUTOC	COMP	PR	CL FS	plcomp90	wrnkvt	numelect
[1,]	0.4918	0.000e+00	-5.551e-17	-0.3371	-0.48636	0	0	0.5340
[2,]	0.2387	-5.551e-17	0.000e+00	0.4917	-0.08336	0	0	-0.1215
	avgvotur							
[1,]	0.1547							
[2,]	-0.6242							

Fraction of Variance

[1]	0.5192	0.8877	0.9536	0.9855	0.9994	1.0000	1.0000	1.0000	1.0000
-----	--------	--------	--------	--------	--------	--------	--------	--------	--------

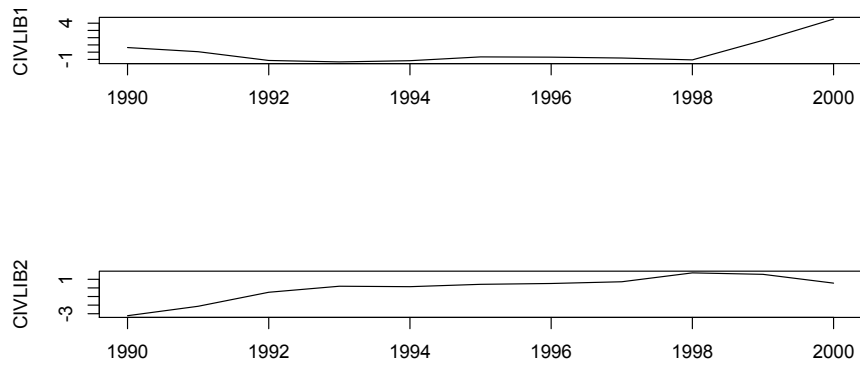

Figure 18: Argentina Civil Liberties Index

Argentina National Social Investment Index

Output Measurement Model

Measurement Matrix

	OBD	HEP	PED	CGDT	GRGDP
[1,]	-0.1655	0.5170	0.5774	0	0.6098
[2,]	0.9336	0.2967	0.1466	0	-0.1370

Fraction of Variance

[1]	0.6137	0.8753	0.9765	1.0000	1.0000
-----	--------	--------	--------	--------	--------

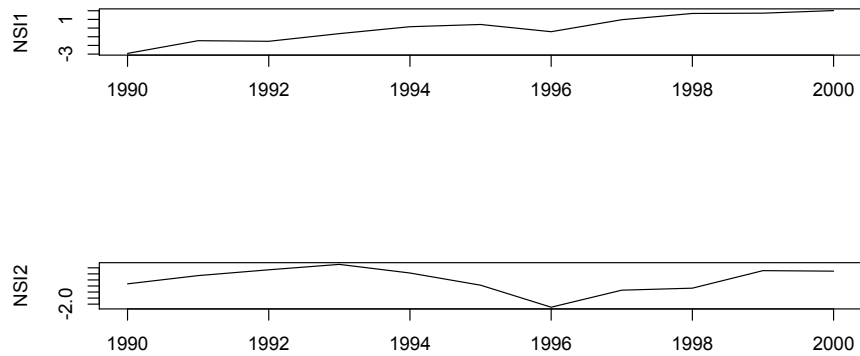

Figure 19: Argentina National Social Investment Index

Argentina Economic Index

Output Measurement Model

	INDEF	EN.ATM.CO2E.KT	NY.GDP.MKTP.KD	EG.USE.COMM.KT.OE	SL.TLF.TOTL.IN	SP.POP.TOTL
[1,]	-0.3817	0.373	0.3710	0.38484	0.3717	0.38529
[2,]	-0.2354	-0.462	0.5004	-0.02611	-0.5625	-0.08659

KOF

[1,]	0.3780
[2,]	0.3952

Fraction of Variance

[1]	0.9563	0.9856	0.9958	0.9986	0.9996	0.9999	1.0000
-----	--------	--------	--------	--------	--------	--------	--------

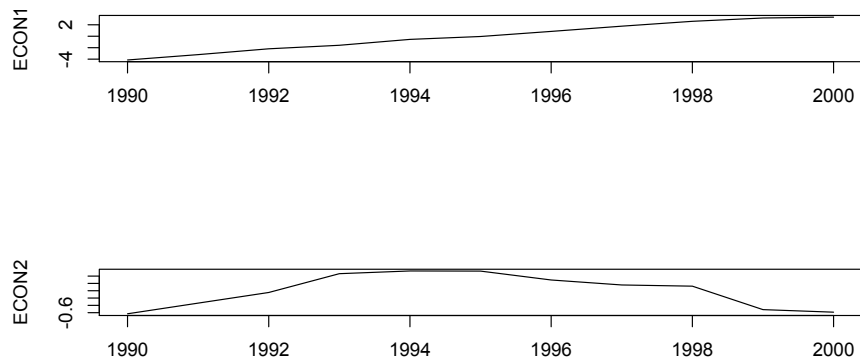

Figure 20: Argentina Economic Index

G.2 Argentina Globalization Index Check

	TX.VAL.SERV.CD.WT	TM.VAL.SERV.CD.WT	IS.SHP.GOOD.TU	IC.EXP.COST.CD
[1,]	0.257900649	0.254980350	-0.25382543	0.25432207
[2,]	-0.024377038	-0.102224240	-0.12912045	-0.11968146
[3,]	0.005451953	-0.004855167	0.06623072	-0.04009948
	IC.IMP.COST.CD	GC.TAX.IMPT.CN	BN.CAB.XOKA.CD	DT.TDS.DECT.CD
[1,]	-0.02624252	0.258160821	0.257366807	0.2301670
[2,]	-0.62231707	-0.012451356	0.054274091	0.1488931
[3,]	-0.69342836	-0.003160682	0.005002453	-0.2621642
	EG.IMP.CONS.ZS	TX.VAL.MRCH.XD.WD	TX.QTY.MRCH.XD.WD	NE.RSB.GNFS.CD
[1,]	-0.20813759	0.23956899	0.252377802	0.1440999
[2,]	-0.34343253	-0.25470320	-0.008168686	-0.4456856
[3,]	0.08325771	-0.02268708	-0.022811424	0.6127038
	DT.DOD.DECT.CD	BN.KLT.DINV.CD	PA.NUS.FCRF	IQ.WEF.PORT.XQ
[1,]	0.25054892	0.25623676	0.2135622	0.25746781
[2,]	0.13538480	0.08980312	-0.3427993	-0.03174758
[3,]	-0.06936302	0.01480783	0.2164162	0.02171367
	TM.TAX.MRCH.SM.AR.ZS	GC.TAX.INTT.RV.ZS		

[1,]	-0.24915817	0.25540322
[2,]	-0.08649115	0.10722049
[3,]	0.08812397	-0.02945522

	GLOB1	GLOB2	GLOB3
KOF	0.9210947	0.4525856	-0.004013803

N = 53

G.3 AR: Testing Model Assumptions

PROTEST MODEL

Coefficients:

(Intercept)	IMFP2	STHARD2
-5.890e-16	-3.648e-01	2.144e+00

Shapiro-Wilk normality test

W = 0.932, p-value = 0.432

Breusch-Godfrey test for serial correlation of order up to 1

data: PROT1 ~ IMFP2 + STHARD2

LM test = 3.5989, df = 1, p-value = 0.05782

HARDSHIP MODEL

Coefficients:

(Intercept)	IMFP2	LTHARD2	NSI2	CIVLIB2
6.580e-18	5.788e-01	1.212e-01	-8.361e-02	-1.806e-01
ECON2				
1.381e+00				

Shapiro-Wilk normality test

W = 0.9713, p-value = 0.8997

Breusch-Godfrey test for serial correlation of order up to 1

data: STHARD2 ~ IMFP2 + LTHARD2 + NSI2 + CIVLIB2 + ECON2

LM test = 0.9459, df = 1, p-value = 0.3308

G.4 AR Granger Causality Testing

```

Granger Test
              F-statistic      p-value
ECON2 -> IMFP2      12.083587047 0.0103198415
IMFP2 -> STHARD2    31.425891544 0.0008109475
CIVLIB2 -> STHARD2  14.375673586 0.0067893681
ECON2 -> STHARD2    13.846724333 0.0074451176
PROT2 -> NSI2       5.919146219 0.0452256950
IMFP2 -> NSI2      10.041849304 0.0157322083

```

```
max.lag = 1
```

G.5 AR Path Models

	PROT1	IMFP2	STHARD2	LTHARD2	CIVLIB2	ECON2
PROT1	1.00	0.05	0.59	0.31	-0.39	0.30
IMFP2	0.05	1.00	0.37	0.50	0.63	-0.66
STHARD2	0.59	0.37	1.00	0.51	-0.08	0.24
LTHARD2	0.31	0.50	0.51	1.00	-0.09	-0.37
CIVLIB2	-0.39	0.63	-0.08	-0.09	1.00	-0.37
ECON2	0.30	-0.66	0.24	-0.37	-0.37	1.00

FEEDFORWARD MODEL

AIC = 32.433

Parameter Estimates

	Estimate	Std Error	z value	Pr(> z)	
p41	0.711470	0.23388	3.04202	2.3500e-03	STHARD2 <--- IMFP2
p42	0.489507	0.19028	2.57260	1.0094e-02	STHARD2 <--- LTHARD2
p43	0.890985	0.21891	4.07011	4.6991e-05	STHARD2 <--- ECON2
p54	-0.075266	0.31533	-0.23869	8.1135e-01	CIVLIB2 <--- STHARD2
p56	0.511270	0.24598	2.07853	3.7660e-02	PROT1 <--- STHARD2
p65	-0.435520	0.22863	-1.90491	5.6792e-02	PROT1 <--- CIVLIB2
p61	0.136086	0.24537	0.55461	5.7916e-01	PROT1 <--- IMFP2
E6	0.519757	0.23244	2.23607	2.5347e-02	PROT1 <--> PROT1
E5	0.994335	0.44468	2.23607	2.5347e-02	CIVLIB2 <--> CIVLIB2
E4	0.271675	0.12150	2.23607	2.5347e-02	STHARD2 <--> STHARD2

Iterations = 0

FEEDBACK MODEL

AIC = 52.508

Parameter Estimates

	Estimate	Std Error	z value	Pr(> z)	
p41	0.52392	0.35603	1.47157	0.141137	IMFP2 <--- STHARD2
p42	0.51003	0.27201	1.87507	0.060783	LTHARD2 <--- STHARD2
p43	0.24196	0.30683	0.78856	0.430369	ECON2 <--- STHARD2
p54	0.18346	0.26984	0.67990	0.496570	STHARD2 <--- CIVLIB2

```

p56 0.66568 0.26984 2.46692 0.013628 STHARD2 <--- PROT1
p65 -0.38867 0.29136 -1.33397 0.182213 CIVLIB2 <--- PROT1
p61 -0.25935 0.35603 -0.72844 0.466345 IMFP2 <--- PROT1
E6 0.81977 0.36661 2.23607 0.025347 IMFP2 <--> IMFP2
E5 0.84893 0.37965 2.23607 0.025347 CIVLIB2 <--> CIVLIB2
E4 0.61815 0.27644 2.23607 0.025347 STHARD2 <--> STHARD2
E3 0.94146 0.42103 2.23607 0.025347 ECON2 <--> ECON2
E2 0.73987 0.33088 2.23607 0.025347 LTHARD2 <--> LTHARD2

```

Iterations = 0

SIMPLIFIED FEEDFORWARD MODEL

AIC = 19.122

Parameter Estimates

	Estimate	Std Error	z value	Pr(> z)	
p41	0.71147	0.23388	3.0420	2.3500e-03	STHARD2 <--- IMFP2
p42	0.48951	0.19028	2.5726	1.0094e-02	STHARD2 <--- LTHARD2
p43	0.89098	0.21891	4.0701	4.6991e-05	STHARD2 <--- ECON2
p56	0.51127	0.25191	2.0296	4.2401e-02	PROT1 <--- STHARD2
p65	-0.43552	0.30046	-1.4495	1.4719e-01	PROT1 <--- CIVLIB2
p61	0.13609	0.32263	0.4218	6.7317e-01	PROT1 <--- IMFP2
E6	0.51976	0.23244	2.2361	2.5347e-02	PROT1 <--> PROT1
E4	0.27167	0.12150	2.2361	2.5347e-02	STHARD2 <--> STHARD2

Iterations = 0

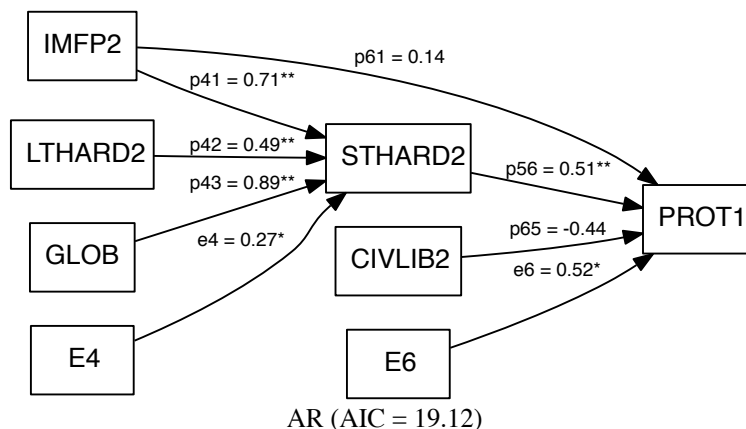

Figure 21: Argentina Simplified Feedforward Path Model (* = $p \leq 0.05$, ** = $p \leq 0.01$)

H Brazil

H.1 Index Construction

Brazil Protest

Output Measurement Model

Measurement Matrix

	FREQ	CITIES	DURATION	SEVERITY	FORM	PARTIC
[1,]	0.4463	0.1955	0.4151	0.4521	0.4466	0.43178
[2,]	-0.1819	0.9465	-0.2043	0.0738	-0.1507	0.03436

Fraction of Variance

[1]	0.7973	0.9482	0.9831	0.9956	0.9990	1.0000
-----	--------	--------	--------	--------	--------	--------

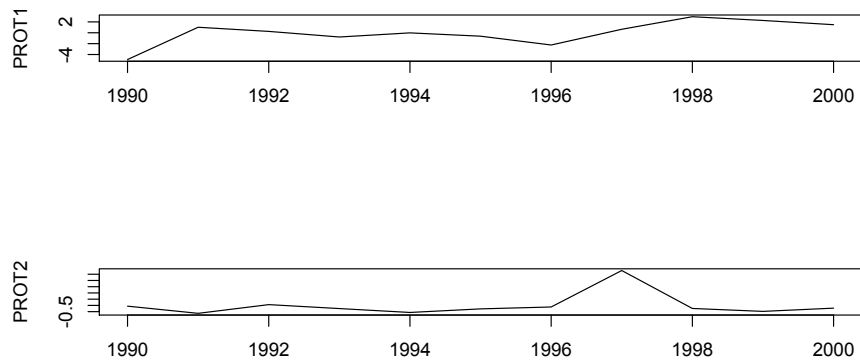

Figure 22: Brazil Protest Index

Brazil IMF Pressure Index

Output Measurement Model

Measurement Matrix

	IMFCR	LNQTA	EXFD	DBTEX	EXDTC	STDBT	INDETLVL	RENEGCM	RENEGOF
[1,]	0.4105	-0.1665	0.4386	0.4556	0.4484	-0.45024	0	0	0
[2,]	0.3989	0.8358	0.2675	-0.1223	-0.2329	-0.04053	0	0	0
[3,]	0.4749	-0.4288	0.4199	-0.1956	-0.2389	0.56478	0	0	0

Fraction of Variance

[1]	0.7580	0.9584	0.9858	0.9959	0.9989	1.0000	1.0000	1.0000	1.0000
-----	--------	--------	--------	--------	--------	--------	--------	--------	--------

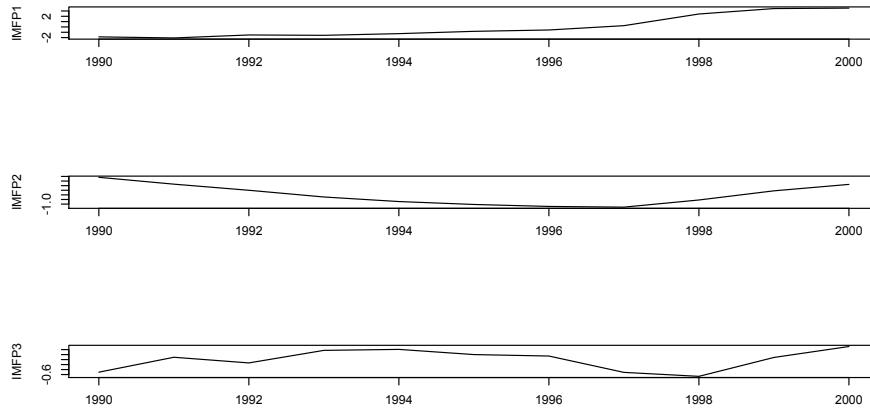

Figure 23: Brazil IMF Pressure Index

Brazil Short-term Hardship Index

Output Measurement Model

Measurement Matrix

	UNEM	HPI1RK	HPIVAL	PVLN8994	PVLNNATI	HCE	CPI	INFLA
[1,]	0.4118	-1.110e-16	-3.469e-18	0.000e+00	0	0.46476	0.4628	-0.4351
[2,]	0.8912	0.000e+00	2.776e-17	-1.735e-18	0	-0.05776	-0.1991	0.1997

fpi90

[1,]	0.4593
[2,]	-0.3507

Fraction of Variance

[1]	0.8989	0.9586	0.9946	0.9998	1.0000	1.0000	1.0000	1.0000	1.0000
-----	--------	--------	--------	--------	--------	--------	--------	--------	--------

Brazil Long-term Hardship

Output Measurement Model

Measurement Matrix

	HEP	ACSW9097	ACSN9097	CIFPINEQ	MRI	LEB	SL.UEM.LTRM.ZS
[1,]	0.3715	0.000e+00	2.776e-17	0	-0.4506	0.44742	0
[2,]	-0.4483	1.041e-16	2.220e-16	0	-0.1322	0.08716	0

	SL.UEM.TOTL.ZS	SL.FAM.WORK.ZS	SL.TLF.0714.ZS	SL.TLF.PART.ZS
[1,]	0.4563	0.2310	0.4441	0
[2,]	-0.0283	0.8413	-0.2556	0

Fraction of Variance

[1]	0.7379	0.8921	0.9697	0.9881	1.0000	1.0000	1.0000	1.0000	1.0000
[11]	1.0000								

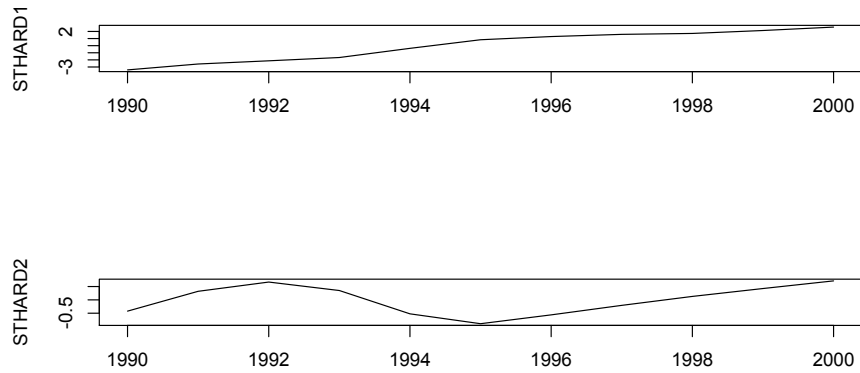

Figure 24: Brazil Short-term hardship Index

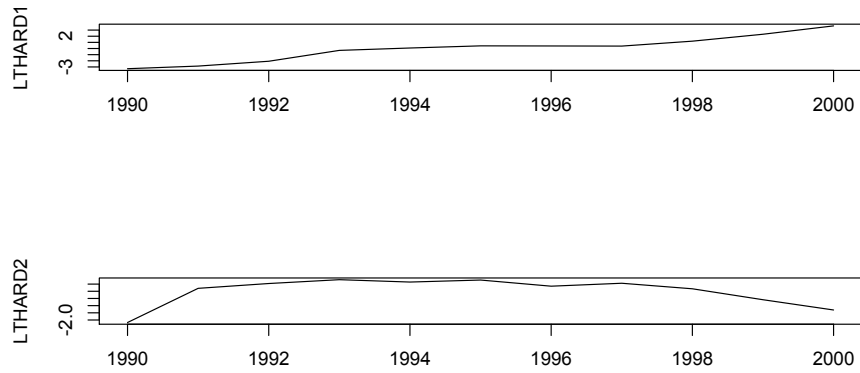

Figure 25: Brazil Long-term Hardship Index

Brazil Civil Liberties Index

Output Measurement Model

Measurement Matrix

	DEMOC	AUTOC	COMP	PR	CL	FS	plcomp90	wrnkvt
[1,]	0	0.000e+00	0.000e+00	0.3747	0.2821	-0.4239	0	0.47535
[2,]	0	-5.551e-17	-1.110e-16	-0.1807	0.7352	-0.4063	0	-0.08008
	numelect	avgvotur						
[1,]	0.4502	-0.4143						
[2,]	-0.1704	0.4757						

Fraction of Variance

[1]	0.6971	0.8927	0.9740	0.9909	0.9969	1.0000	1.0000	1.0000	1.0000
-----	--------	--------	--------	--------	--------	--------	--------	--------	--------

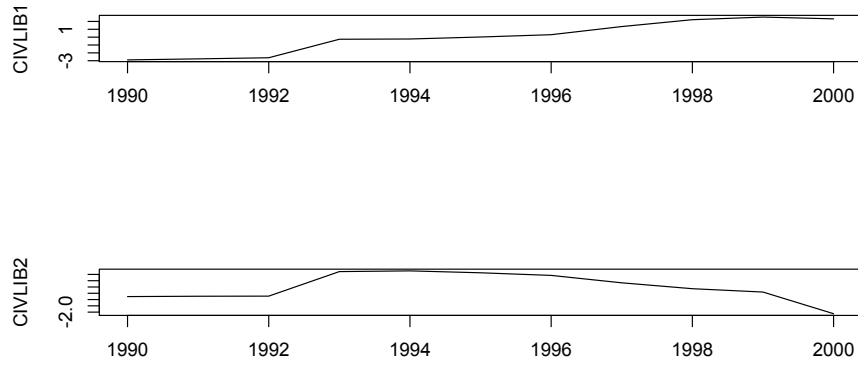

Figure 26: Brazil Civil Liberties Index

Brazil National Social Investment Index

Output Measurement Model

Measurement Matrix

	OBD	HEP	PED	CGDT	GRGDP
[1,]	0.5046	0.5794	0.6401	0	0
[2,]	0.8128	-0.5688	-0.1259	0	0

Fraction of Variance

[1]	0.6664	0.9015	1.0000	1.0000	1.0000
-----	--------	--------	--------	--------	--------

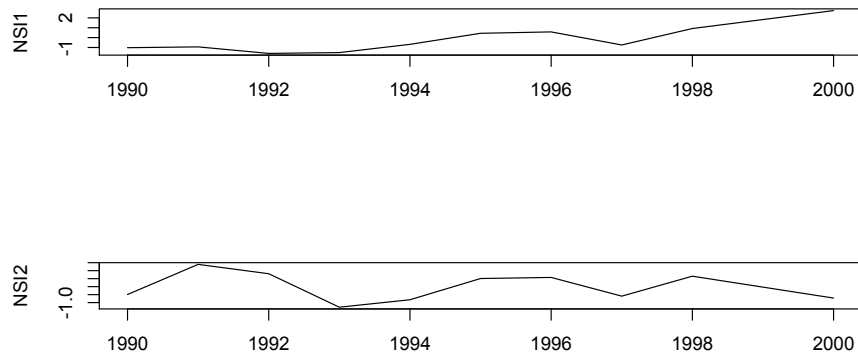

Figure 27: Brazil National Social Investment Index

Brazil Economic Index

Output Measurement Model

Measurement Matrix

	INDEF	EN.ATM.CO2E.KT	NY.GDP.MKTP.KD	EG.USE.COMM.KT.OE	SL.TLF.TOTL.IN
[1,]	0.3646	0.3790	0.3818	0.3793	0.37908
[2,]	0.7605	-0.2383	-0.1246	-0.4357	-0.01759

	SP.POP.TOTL	KOF
[1,]	0.3828	0.3789
[2,]	-0.2344	0.3227

Fraction of Variance

[1] 0.9571 0.9818 0.9949 0.9988 0.9994 0.9998 1.0000

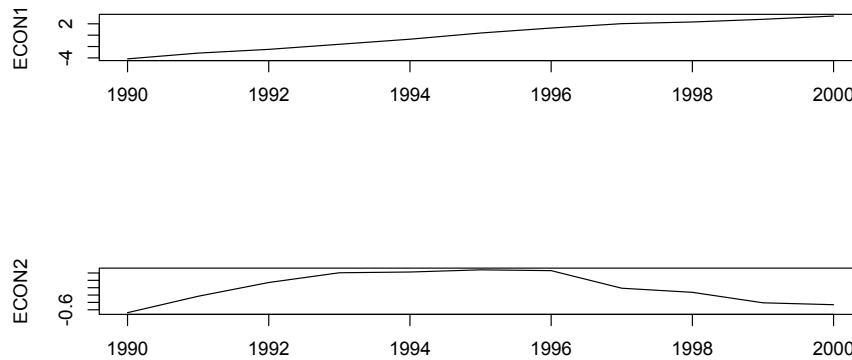

Figure 28: Brazil Economic Index

H.2 Brazil Globalization Index Check

Fraction of Variance Explained = 0.66 0.87 0.94

	TX.VAL.SERV.CD.WT	TM.VAL.SERV.CD.WT	IS.SHP.GOOD.TU	IC.EXP.COST.CD
[1,]	0.29793549	0.29618187	-0.2673427	-0.25244006
[2,]	0.01652130	0.04970521	0.2041170	0.27582666
[3,]	-0.03232798	-0.04528563	0.1404401	-0.04658098

	IC.IMP.COST.CD	GC.TAX.IMPT.CN	BN.CAB.XOKA.CD	DT.TDS.DPNG.CD
[1,]	-0.21425078	0.2182538	0.004659459	0.2579270
[2,]	0.35112191	0.3527303	-0.501959218	0.1245243
[3,]	-0.08896463	0.0410752	0.100005860	0.1586995

	EG.IMP.CONS.ZS	TX.VAL.MRCH.XD.WD	TX.QTY.MRCH.XD.WD	NE.RSB.GNFS.CD
[1,]	-0.1029604	0.27222135	0.29036644	-0.03005088
[2,]	-0.2465386	0.16387047	-0.03326261	-0.35654670
[3,]	-0.6742477	-0.05179415	-0.08477180	0.52799725

	BX.KLT.DINV.CD.WD	PA.NUS.FCRF	IQ.WEF.PORT.XQ	TM.TAX.MRCH.SM.AR.ZS
[1,]	0.29793549	0.29618187	-0.2673427	-0.25244006
[2,]	0.01652130	0.04970521	0.2041170	0.27582666
[3,]	-0.03232798	-0.04528563	0.1404401	-0.04658098

[1,]	0.22868200	0.25154215	-0.29801658	-0.2787706
[2,]	0.32452588	0.05852408	0.03305314	0.1385069
[3,]	-0.03527012	0.33474967	0.01917582	0.1760873

GC.TAX.INTT.RV.ZS

[1,]	0.2760609
[2,]	-0.1394711
[3,]	-0.2056370

	GLOB1	GLOB2	GLOB3
KOF	0.9526026	-0.2875966	0.2181507

N = 53

H.3 BR Testing Model Assumptions

PROTEST MODEL

Coefficients:

(Intercept)	IMFP2	STHARD2
-1.983e-16	-1.200e+00	3.364e+00

Shapiro-Wilk normality test

W = 0.906, p-value = 0.2184

Breusch-Godfrey test for serial correlation of order up to 1

data: PROT1 ~ IMFP2 + STHARD2

LM test = 0.0023, df = 1, p-value = 0.962

HARDSHIP MODEL

Coefficients:

(Intercept)	IMFP2	LTHARD2	NSI2	CIVLIB2
1.257e-16	2.317e-01	6.791e-01	-2.524e-01	-4.884e-01
ECON2				
-3.796e-01				

Shapiro-Wilk normality test

W = 0.9159, p-value = 0.2861

Breusch-Godfrey test for serial correlation of order up to 1

data: STHARD2 ~ IMFP2 + LTHARD2 + NSI2 + CIVLIB2 + ECON2

LM test = 1.9196, df = 1, p-value = 0.1659

H.4 BR Granger Causality Testing

```

Granger Test
              F-statistic      p-value
ECON2 -> IMFP2      3.092417e+01 0.0008500647
LTHARD2 -> STHARD2  4.804487e+00 0.0644962775
CIVLIB2 -> STHARD2  2.405221e+01 0.0017445411
ECON2 -> STHARD2    1.360548e+01 0.0077713523
ECON2 -> CIVLIB2    7.430860e+00 0.0295103695
IMFP2 -> ECON2      1.295573e+01 0.0087467264

```

```
max.lag = 1
```

H.5 BR Path Models

```

          PROT1  IMFP2  STHARD2  LTHARD2  CIVLIB2  ECON2
PROT1      1.00 -0.18    0.54    0.32   -0.22 -0.06
IMFP2     -0.18  1.00    0.51   -0.77   -0.77 -0.79
STHARD2    0.54  0.51    1.00   -0.17   -0.67 -0.43
LTHARD2    0.32 -0.77   -0.17    1.00    0.70  0.87
CIVLIB2   -0.22 -0.77   -0.67    0.70    1.00  0.84
ECON2     -0.06 -0.79   -0.43    0.87    0.84  1.00

```

FEEDFORWARD MODEL

AIC = 35.986

```

Parameter Estimates
      Estimate Std Error z value Pr(>|z|)
p41  0.68080 0.37016    1.8392 0.06588025 STHARD2 <--- IMFP2
p42  1.07156 0.45477    2.3563 0.01845918 STHARD2 <--- LTHARD2
p43 -0.82479 0.47202   -1.7474 0.08057182 STHARD2 <--- ECON2
p54 -0.66574 0.23596   -2.8214 0.00478166 CIVLIB2 <--- STHARD2
p56  0.68908 0.28994    2.3766 0.01747301 PROT1 <--- STHARD2
p65 -0.40995 0.26558   -1.5436 0.12269017 PROT1 <--- CIVLIB2
p61 -0.84134 0.22979   -3.6613 0.00025096 PROT1 <--- IMFP2
E6   0.39273 0.17563    2.2361 0.02534732 PROT1 <--> PROT1
E5   0.55679 0.24900    2.2361 0.02534732 CIVLIB2 <--> CIVLIB2
E4   0.47617 0.21295    2.2361 0.02534732 STHARD2 <--> STHARD2

```

Iterations = 0

FEEDBACK MODEL

AIC = 67.221

```

Parameter Estimates
      Estimate Std Error z value Pr(>|z|)
p41  0.84277 0.25487    3.30673 0.00094391 IMFP2 <--- STHARD2
p42 -0.16683 0.31180   -0.53506 0.59260781 LTHARD2 <--- STHARD2
p43 -0.43399 0.28490   -1.52333 0.12767684 ECON2 <--- STHARD2
p54 -0.57594 0.20416   -2.82096 0.00478804 STHARD2 <--- CIVLIB2

```

```

p56 0.40991 0.20416 2.00774 0.04467081 STHARD2 <--- PROT1
p65 -0.21908 0.30855 -0.71005 0.47767531 CIVLIB2 <--- PROT1
p61 -0.62777 0.25487 -2.46315 0.01377220 IMFP2 <--- PROT1
E6 0.46289 0.20701 2.23607 0.02534732 IMFP2 <--> IMFP2
E5 0.95200 0.42575 2.23607 0.02534732 CIVLIB2 <--> CIVLIB2
E4 0.39682 0.17747 2.23607 0.02534732 STHARD2 <--> STHARD2
E3 0.81165 0.36298 2.23607 0.02534732 ECON2 <--> ECON2
E2 0.97217 0.43477 2.23607 0.02534732 LTHARD2 <--> LTHARD2

```

Iterations = 0

SIMPLIFIED FEEDFORWARD MODEL

AIC = 24.265

Parameter Estimates

	Estimate	Std Error	z value	Pr(> z)	
p41	0.68080	0.37016	1.8392	0.0658803	STHARD2 <--- IMFP2
p42	1.07156	0.45477	2.3563	0.0184592	STHARD2 <--- LTHARD2
p43	-0.82479	0.47202	-1.7474	0.0805718	STHARD2 <--- ECON2
p56	0.68908	0.23185	2.9721	0.0029575	PROT1 <--- STHARD2
p65	-0.40995	0.31464	-1.3029	0.1926023	PROT1 <--- CIVLIB2
p61	-0.84134	0.32326	-2.6027	0.0092492	PROT1 <--- IMFP2
E6	0.39273	0.17563	2.2361	0.0253473	PROT1 <--> PROT1
E4	0.47617	0.21295	2.2361	0.0253473	STHARD2 <--> STHARD2

Iterations = 0

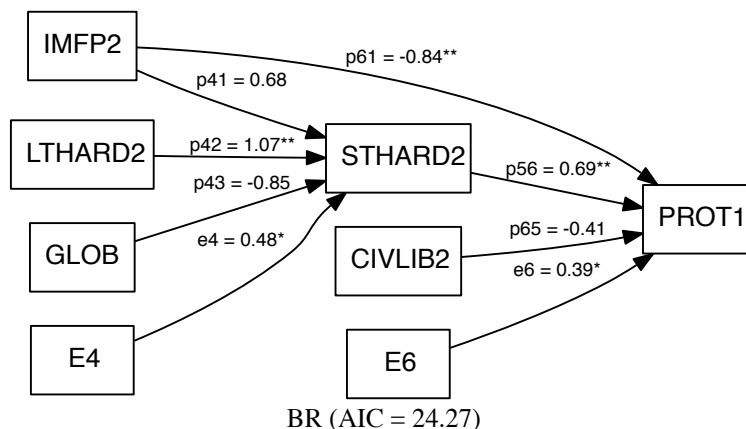

Figure 29: Brazil Simplified Feedforward Path Model (* = $p \leq 0.05$, ** = $p \leq 0.01$)

I Mexico

I.1 Index Construction

Mexico Protest

Output Measurement Model

Measurement Matrix

	FREQ	CITIES	DURATION	SEVERITY	FORM	PARTIC
[1,]	0.4146	0.4120	0.4085	0.41530	0.3857	0.4126
[2,]	-0.2928	-0.2938	0.0894	0.07877	0.8291	-0.3554

Fraction of Variance

[1]	0.9451	0.9813	0.9928	0.9970	0.9997	1.0000
-----	--------	--------	--------	--------	--------	--------

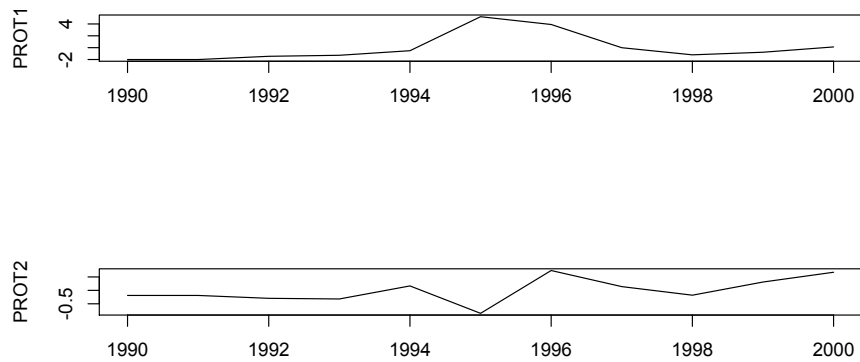

Figure 30: Mexico Protest Index

Mexico IMF Pressure Index

Output Measurement Model

Measurement Matrix

	IMFCR	LNQTA	EXFD	DBTEX	EXDTC	STDBT	INDETLVL	RENEGCM	RENEGOF
[1,]	0.32757	0.54310	0.2398	0.52818	-0.2834	0.4254	0	0	0
[2,]	0.57055	-0.14196	0.6075	-0.03229	0.4736	-0.2449	0	0	0
[3,]	0.03574	0.07343	0.2786	-0.09720	-0.7119	-0.6320	0	0	0

Fraction of Variance

[1]	0.66	0.87	0.9369	0.94	0.9997	1.0000	1.0000	1.0000	1.0000
-----	------	------	--------	------	--------	--------	--------	--------	--------

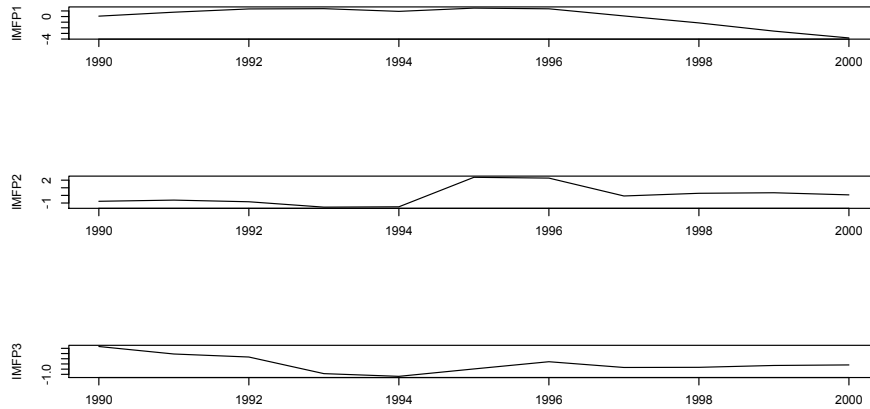

Figure 31: Mexico IMF Pressure Index

Mexico Short-term Hardship Index

Output Measurement Model

Measurement Matrix

	UNEM	HPI1RK	HPIVAL	PVLN8994	PVLNNATI	HCE	CPI	INFLA
[1,]	-0.1507	1.110e-16	0.000e+00	0.000e+00	0	0.4751	0.5094	-0.4863
[2,]	0.8975	8.327e-17	5.551e-17	-1.735e-18	0	0.2082	0.1817	0.2964

 fpi90

[1,]	0.5056
[2,]	0.1738

Fraction of Variance

[1]	0.7244	0.9493	0.9866	0.9997	1.0000	1.0000	1.0000	1.0000	1.0000
-----	--------	--------	--------	--------	--------	--------	--------	--------	--------

Mexico Long-term Hardship

Output Measurement Model

Measurement Matrix

	HEP	ACSW9097	ACSN9097	CIFPINEQ	MRI	LEB	SL.UEM.LTRM.ZS
[1,]	0.3878	-1.110e-16	0	0	-0.4291	0.4592	0.4295
[2,]	-0.3654	-1.665e-16	0	0	0.2867	-0.1717	0.1863

	SL.UEM.TOTL.ZS	SL.FAM.WORK.ZS	SL.TLF.0714.ZS	SL.TLF.PART.ZS
[1,]	0.2857	-0.03709	0.2702	0.3379
[2,]	0.4877	0.60349	0.2558	0.2294

Fraction of Variance

[1]	0.5473	0.8109	0.9206	0.9651	0.9879	0.9981	0.9998	1.0000	1.0000	1.0000
[11]	1.0000									

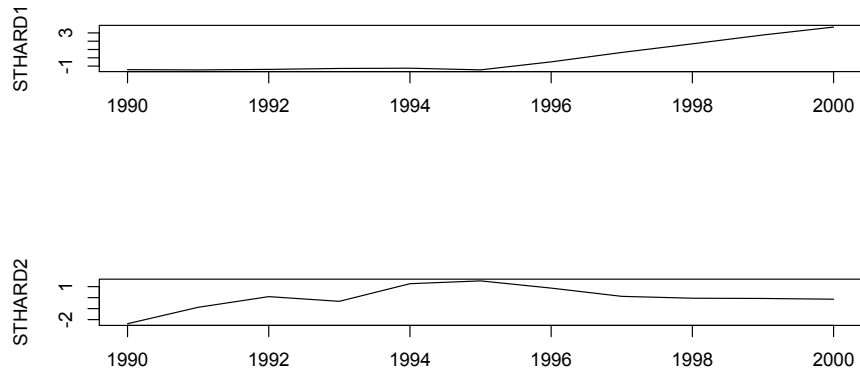

Figure 32: Mexico Short-term hardship Index

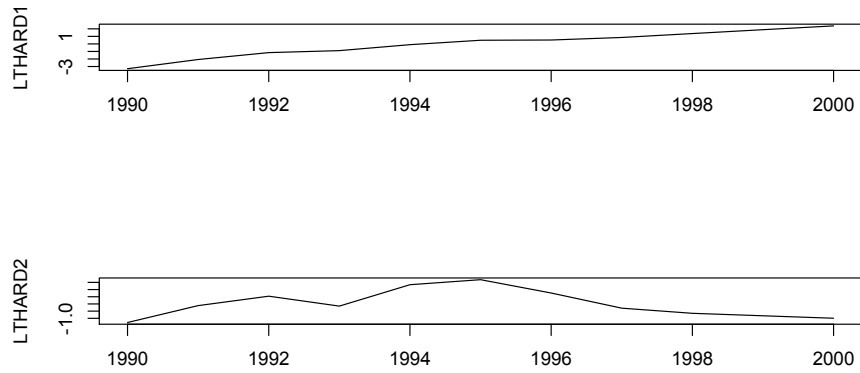

Figure 33: Mexico Long-term Hardship Index

Mexico Civil Liberties Index

Output Measurement Model

Measurement Matrix

	DEMOC	AUTOC	COMP	PR	CL	FS	plcomp90	wrnkvt	numelect
[1,]	0.43724	-0.3467	0.3501	-0.4098	-0.1278	0.32029	0.000e+00	0.2901	0.43667
[2,]	-0.07521	-0.1275	-0.3027	0.2078	-0.2164	0.03713	1.735e-18	0.5397	0.06988
	avgvotur								
[1,]	-0.06623								
[2,]	0.70639								

Fraction of Variance

[1]	0.5567	0.7559	0.8957	0.9546	0.9852	0.9984	0.9993	1.0000	1.0000	1.0000
-----	--------	--------	--------	--------	--------	--------	--------	--------	--------	--------

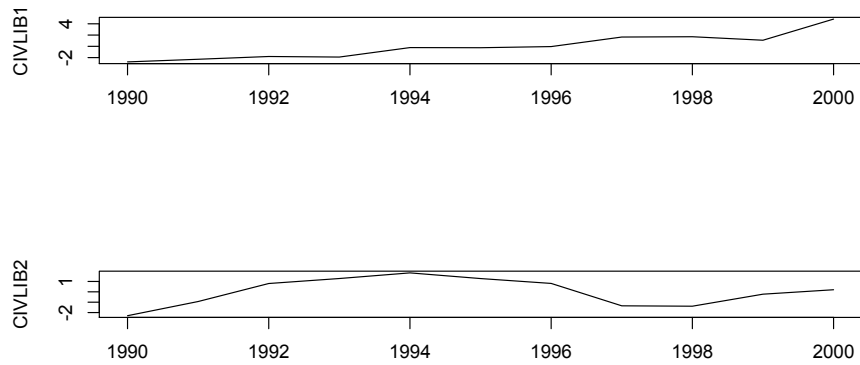

Figure 34: Mexico Civil Liberties Index

Mexico National Social Investment Index

Output Measurement Model

Measurement Matrix

	OBD	HEP	PED	CGDT	GRGDP
[1,]	0.07715	-0.62389	-0.6433	0.4370	0
[2,]	0.84738	-0.06378	-0.1744	-0.4975	0

Fraction of Variance

[1]	0.5707	0.8728	0.9949	1.0000	1.0000
-----	--------	--------	--------	--------	--------

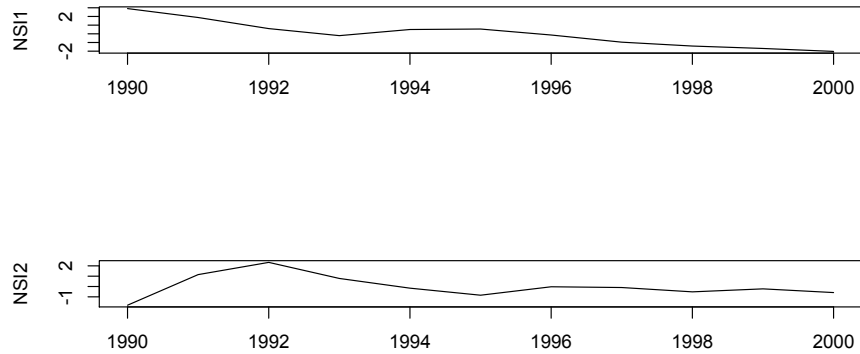

Figure 35: Mexico National Social Investment Index

Mexico Economic Index

Output Measurement Model

Measurement Matrix

	INDEF	EN.ATM.CO2E.KT	NY.GDP.MKTP.KD	EG.USE.COMM.KT.OE	SL.TLF.TOTL.IN
[1,]	0.3793	0.3994	0.3885	0.3956	0.40629
[2,]	0.2484	-0.1576	-0.3099	-0.2184	-0.04338

	SP.POP.TOTL	KOF
[1,]	0.40673	0.2421
[2,]	-0.04592	0.8750

Fraction of Variance

[1] 0.8452 0.9608 0.9903 0.9969 0.9991 0.9999 1.0000

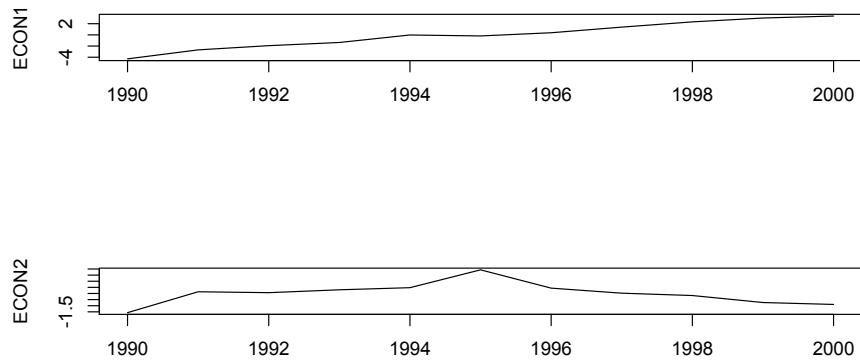

Figure 36: Mexico Economic Index

I.2 Mexico Globalization Index Check

Fraction of Variance Explained = 0.66 0.87 0.94

	TX.VAL.SERV.CD.WT	TM.VAL.SERV.CD.WT	IS.SHP.GOOD.TU	IC.EXP.COST.CD
[1,]	-0.26424033	0.27281915	0.1358098	0.272766576
[2,]	0.11649306	-0.06880411	0.4870662	-0.008122985
[3,]	0.02173853	-0.02582911	0.6436393	0.051838548

	IC.IMP.COST.CD	GC.TAX.IMPT.CN	BN.CAB.XOKA.CD	DT.TDS.DPNG.CD
[1,]	0.271629392	0.272550396	0.26374879	0.24328485
[2,]	-0.049177405	-0.004057216	-0.14530024	0.10050873
[3,]	-0.002353857	0.063828361	-0.06867547	-0.08913512

	EG.IMP.CONS.ZS	TX.VAL.MRCH.XD.WD	TX.QTY.MRCH.XD.WD	NE.RSB.GNFS.CD
[1,]	-0.05179299	0.2641549	0.26355797	-0.1774007
[2,]	0.57547910	0.1459196	0.14638626	-0.3621853
[3,]	-0.54400975	0.1618378	0.09563104	0.4040466

	BX.KLT.DINV.CD.WD	PA.NUS.FCRF	IQ.WEF.PORT.XQ	TM.TAX.MRCH.SM.AR.ZS
[1,]	0.24204794	0.25543111	-0.2614899	-0.25646963

[2,]	0.12453645	0.15527081	0.1699283	0.18914426
[3,]	-0.04751608	0.08200009	0.1546966	0.06325513
	GC.TAX.INTT.RV.ZS			
[1,]	0.2338881			
[2,]	-0.3184359			
[3,]	-0.1836013			

	GLOB1	GLOB2	GLOB3
KOF	0.9487898	-0.1112645	-0.1288218

N = 53

I.3 MX Testing Model Assumptions

PROTEST MODEL

Coefficients:

(Intercept)	IMFP2	STHARD2
-3.681e-17	1.275e+00	8.350e-01

Shapiro-Wilk normality test

W = 0.9235, p-value = 0.349

Breusch-Godfrey test for serial correlation of order up to 1

data: PROT1 ~ IMFP2 + STHARD2

LM test = 0.7696, df = 1, p-value = 0.3803

HARDSHIP MODEL

Coefficients:

(Intercept)	IMFP2	LTHARD2	NSI2	CIVLIB2
-3.032e-16	1.979e-01	-3.721e-02	-4.730e-02	3.977e-01
	ECON2			
	4.754e-01			

Shapiro-Wilk normality test

W = 0.9398, p-value = 0.5186

Breusch-Godfrey test for serial correlation of order up to 1

data: STHARD2 ~ IMFP2 + LTHARD2 + NSI2 + CIVLIB2 + ECON2

LM test = 0.0049, df = 1, p-value = 0.9441

I.4 MX Granger Causality Testing

Granger Test

	F-statistic	p-value
IMFP2 -> PROT2	6.6958032778	0.03606935
CIVLIB2 -> LTHARD2	6.8475902055	0.03457019
ECON2 -> LTHARD2	7.0062425527	0.03308879
LTHARD2 -> CIVLIB2	8.6476133696	0.02169220
STHARD2 -> NSI2	5.9071845630	0.04538922

max.lag = 1

I.5 MX Path Models

	PROT1	IMFP2	STHARD2	LTHARD2	CIVLIB2	ECON2
PROT1	1.00	0.88	0.70	0.47	0.45	0.68
IMFP2	0.88	1.00	0.46	0.30	0.09	0.43
STHARD2	0.70	0.46	1.00	0.27	0.76	0.80
LTHARD2	0.47	0.30	0.27	1.00	0.12	0.46
CIVLIB2	0.45	0.09	0.76	0.12	1.00	0.65
ECON2	0.68	0.43	0.80	0.46	0.65	1.00

FEEDFORWARD MODEL

AIC = 27.75

Parameter Estimates

	Estimate	Std Error	z value	Pr(> z)	
p41	0.163828	0.202509	0.80899	4.1852e-01	STHARD2 <--- IMFP2
p42	-0.149677	0.206137	-0.72611	4.6777e-01	STHARD2 <--- LTHARD2
p43	0.797061	0.217768	3.66015	2.5207e-04	STHARD2 <--- ECON2
p54	0.760447	0.205358	3.70302	2.1304e-04	CIVLIB2 <--- STHARD2
p56	0.066025	0.151305	0.43637	6.6257e-01	PROT1 <--- STHARD2
p65	0.333525	0.143306	2.32736	1.9946e-02	PROT1 <--- CIVLIB2
p61	0.817168	0.104963	7.78531	6.9540e-15	PROT1 <--- IMFP2
E6	0.086607	0.038732	2.23607	2.5347e-02	PROT1 <--> PROT1
E5	0.421721	0.188599	2.23607	2.5347e-02	CIVLIB2 <--> CIVLIB2
E4	0.328147	0.146752	2.23607	2.5347e-02	STHARD2 <--> STHARD2

Iterations = 0

FEEDBACK MODEL

AIC = 37.505

Parameter Estimates

	Estimate	Std Error	z value	Pr(> z)	
p41	-0.28977	0.191923	-1.50982	1.3109e-01	IMFP2 <--- STHARD2
p42	0.26929	0.304546	0.88422	3.7658e-01	LTHARD2 <--- STHARD2
p43	0.79842	0.190400	4.19338	2.7482e-05	ECON2 <--- STHARD2
p54	0.55904	0.182724	3.05947	2.2173e-03	STHARD2 <--- CIVLIB2
p56	0.44397	0.182724	2.42975	1.5109e-02	STHARD2 <--- PROT1

```

p65 0.45364 0.281817 1.60971 1.0746e-01 CIVLIB2 <--- PROT1
p61 1.07837 0.191923 5.61879 1.9230e-08 IMFP2 <--- PROT1
E6 0.18910 0.084569 2.23607 2.5347e-02 IMFP2 <--> IMFP2
E5 0.79421 0.355180 2.23607 2.5347e-02 CIVLIB2 <--> CIVLIB2
E4 0.26517 0.118588 2.23607 2.5347e-02 STHARD2 <--> STHARD2
E3 0.36252 0.162125 2.23607 2.5347e-02 ECON2 <--> ECON2
E2 0.92749 0.414784 2.23607 2.5347e-02 LTHARD2 <--> LTHARD2

```

Iterations = 0

SIMPLIFIED FEEDFORWARD MODEL

AIC = 25.496

Parameter Estimates

	Estimate	Std Error	z value	Pr(> z)	
p41	0.163828	0.202509	0.80899	4.1852e-01	STHARD2 <--- IMFP2
p42	-0.149677	0.206137	-0.72611	4.6777e-01	STHARD2 <--- LTHARD2
p43	0.797061	0.217768	3.66015	2.5207e-04	STHARD2 <--- ECON2
p56	0.066025	0.124268	0.53131	5.9520e-01	PROT1 <--- STHARD2
p65	0.333525	0.110585	3.01600	2.5613e-03	PROT1 <--- CIVLIB2
p61	0.817168	0.107103	7.62972	2.3526e-14	PROT1 <--- IMFP2
E6	0.086607	0.038732	2.23607	2.5347e-02	PROT1 <--> PROT1
E4	0.328147	0.146752	2.23607	2.5347e-02	STHARD2 <--> STHARD2

Iterations = 0

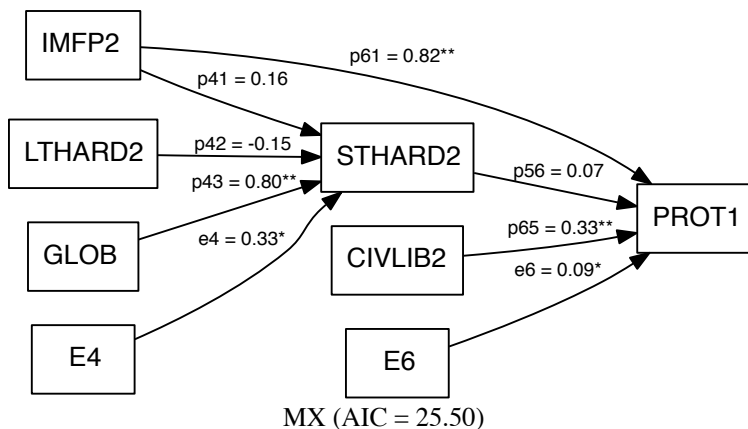

Figure 37: Mexico Simplified Feedforward Path Model (* = $p \leq 0.05$, ** = $p \leq 0.01$)

MODIFIED FEEDFORWARD MODEL

AIC = 14.782

Parameter Estimates

	Estimate	Std Error	z value	Pr(> z)	
p41	0.126740	0.308067	0.4114	6.8078e-01	LTHARD2 <--- IMFP2
p43	0.408630	0.308067	1.3264	1.8470e-01	LTHARD2 <--- ECON2
p56	0.192947	0.080097	2.4089	1.6000e-02	PROT1 <--- LTHARD2
p65	0.364075	0.076610	4.7523	2.0109e-06	PROT1 <--- CIVLIB2
p61	0.786606	0.077287	10.1778	2.4923e-24	PROT1 <--- IMFP2
E6	0.054244	0.024259	2.2361	2.5347e-02	PROT1 <--> PROT1
E4	0.772252	0.345362	2.2361	2.5347e-02	LTHARD2 <--> LTHARD2

Iterations = 0

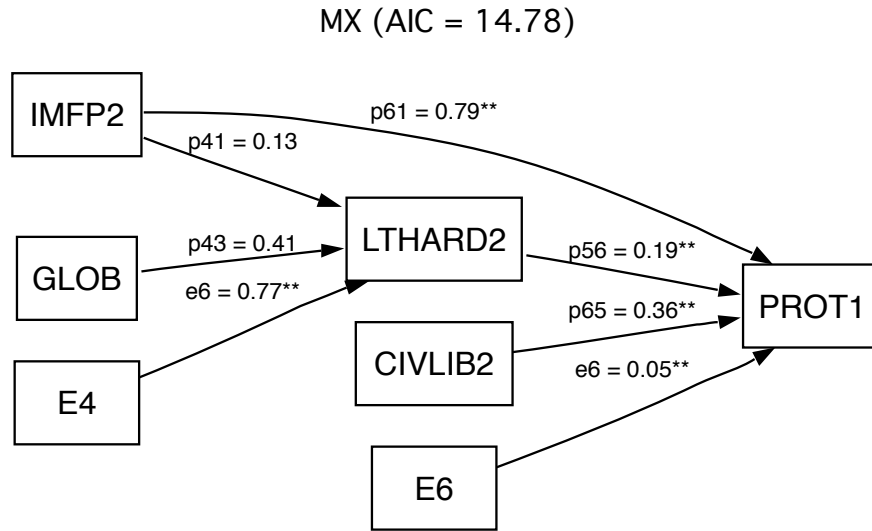

Figure 38: Mexico Modified Feedforward Path Model (* = $p \leq 0.05$, ** = $p \leq 0.01$)

J Venezuela

J.1 Index Construction

Venezuela Protest

Output Measurement Model

Measurement Matrix

	FREQ	CITIES	DURATION	SEVERITY	FORM	PARTIC
[1,]	0.4126	0.4011	0.4051	0.4069	0.4126	0.4110
[2,]	0.2949	-0.5216	0.5688	-0.4204	-0.2283	0.2976

Fraction of Variance

[1]	0.9621	0.9861	0.9957	0.9983	0.9995	1.0000
-----	--------	--------	--------	--------	--------	--------

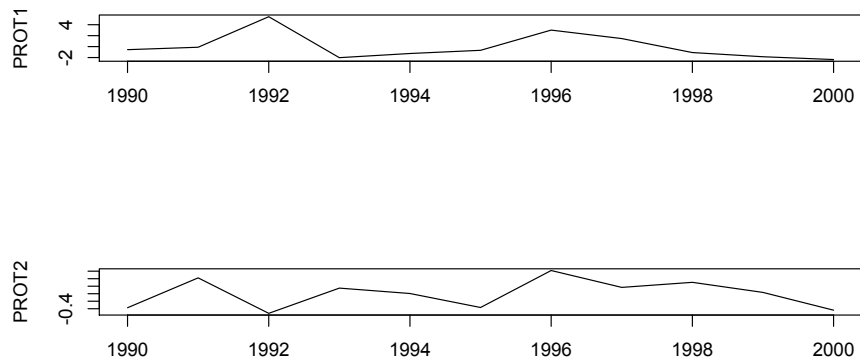

Figure 39: Venezuela Protest Index

Venezuela IMF Pressure Index

Output Measurement Model

Measurement Matrix

	IMFCR	LNQTA	EXFD	DBTEX	EXDTO	INDETLVL	RENEGCM	RENEGOF
[1,]	0.5464	0.59256	0.2970	0.38791	0.3341	0	0	0
[2,]	0.2252	-0.08259	0.7449	-0.58995	-0.1990	0	0	0
[3,]	-0.4385	-0.16057	0.2812	-0.07166	0.8353	0	0	0

Fraction of Variance

[1]	0.4889	0.6984	0.8825	0.9885	1.0000	1.0000	1.0000	1.0000
-----	--------	--------	--------	--------	--------	--------	--------	--------

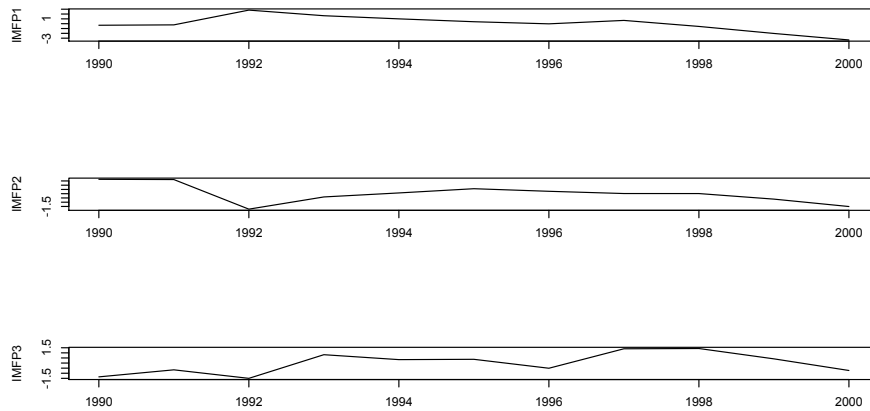

Figure 40: Venezuela IMF Pressure Index

Venezuela Short-term Hardship Index

Output Measurement Model

Measurement Matrix

	UNEM	HPIVAL	PVLN8994	PVLNNATI	HCE	CPI	INFLA	fpi90
[1,]	0.1896	-4.441e-16	0	0.000e+00	-0.3235	0.5393	-0.5340	0.5323
[2,]	0.7510	8.327e-17	0	5.551e-17	-0.5536	-0.2441	0.1212	-0.2350

Fraction of Variance

[1]	0.6146	0.8318	0.9895	0.9998	1.0000	1.0000	1.0000	1.0000
-----	--------	--------	--------	--------	--------	--------	--------	--------

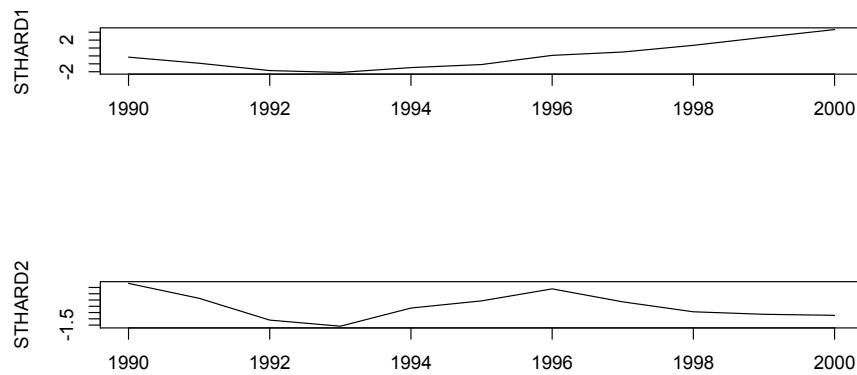

Figure 41: Venezuela Short-term hardship Index

Venezuela Long-term Hardship

Output Measurement Model

Measurement Matrix

	HEP	ACSW9097	ACSN9097	CIFPINEQ	MRI	LEB	SL.UEM.LTRM.ZS	
[1,]	-0.2129	0.000e+00	0.000e+00	-4.337e-19	-0.4198	0.4181		0
[2,]	0.9656	-1.110e-16	2.776e-17	0.000e+00	-0.1919	0.1031		0
	SL.UEM.TOTL.ZS	SL.FAM.WORK.ZS	SL.TLF.0714.ZS	SL.TLF.PART.ZS				
[1,]	0.3073	0.387466	-0.42097		0.42644			
[2,]	0.0998	-0.009915	-0.09263		0.03776			

Fraction of Variance

[1]	0.7618	0.8773	0.9598	0.9952	0.9993	1.0000	1.0000	1.0000	1.0000	1.0000
[11]	1.0000									

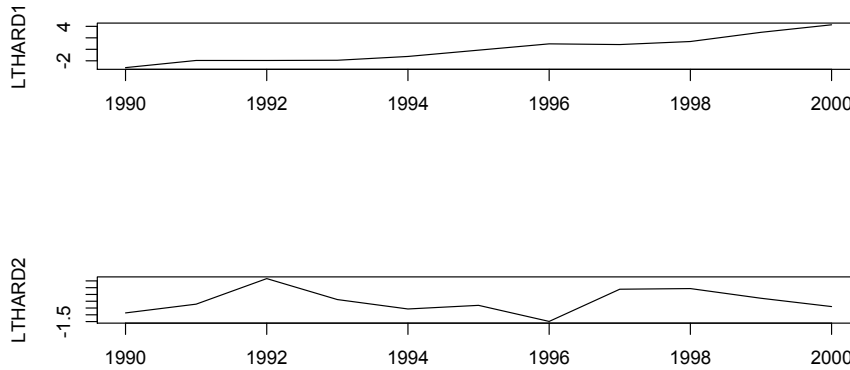

Figure 42: Venezuela Long-term Hardship Index

Venezuela Civil Liberties Index

Output Measurement Model

Measurement Matrix

	DEMOC	AUTOC	COMP	PR	CL	FS	plcomp90	wrnkvt	numelect	
[1,]	0.4446	0.000e+00	0.4060	-0.3974	-0.2723	0.2856		0	-0.3661	-0.3788
[2,]	0.1287	-2.082e-16	-0.2447	-0.1373	-0.4790	0.3376		0	0.3837	-0.1004
	avgvotur									
[1,]	-0.2152									
[2,]	0.6356									

Fraction of Variance

[1]	0.5924	0.8273	0.9703	0.9827	0.9934	0.9996	1.0000	1.0000	1.0000	1.0000
-----	--------	--------	--------	--------	--------	--------	--------	--------	--------	--------

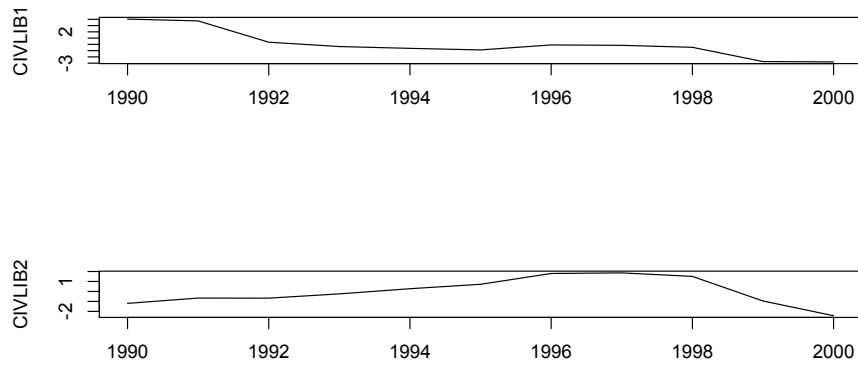

Figure 43: Venezuela Civil Liberties Index

Venezuela National Social Investment Index

Output Measurement Model

Measurement Matrix

	OBD	HEP	PED	CGDT	GRGDP
[1,]	0.1754	-0.5007	0.6372	0	-0.5589
[2,]	0.7732	-0.4056	-0.1163	0	0.4734

Fraction of Variance

[1]	0.4601	0.7875	0.9293	1.0000	1.0000
-----	--------	--------	--------	--------	--------

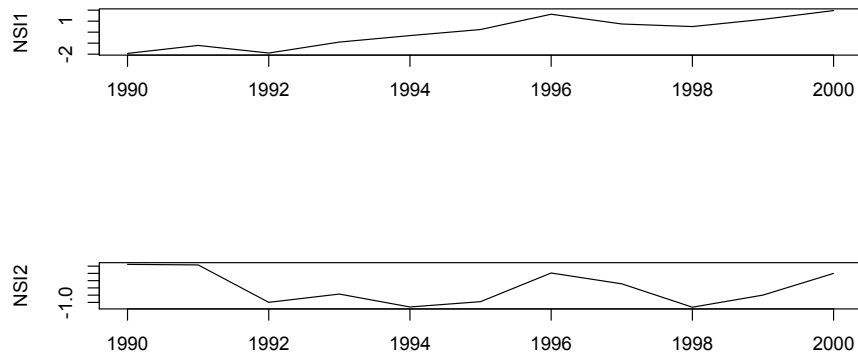

Figure 44: Venezuela National Social Investment Index

Venezuela Economic Index

Output Measurement Model

Measurement Matrix

	INDEF	EN.ATM.CO2E.KT	NY.GDP.MKTP.KD	EG.USE.COMM.KT.OE	SL.TLF.TOTL.IN	SP.POP.TOTL
[1,]	0.3878	0.3200	0.3630	0.3825	0.3957	0.3987
[2,]	0.1619	-0.7748	0.4572	0.2082	-0.2058	-0.1683

KOF

[1,]	0.3920
[2,]	0.2247

Fraction of Variance

[1] 0.8634 0.9469 0.9695 0.9832 0.9935 1.0000 1.0000

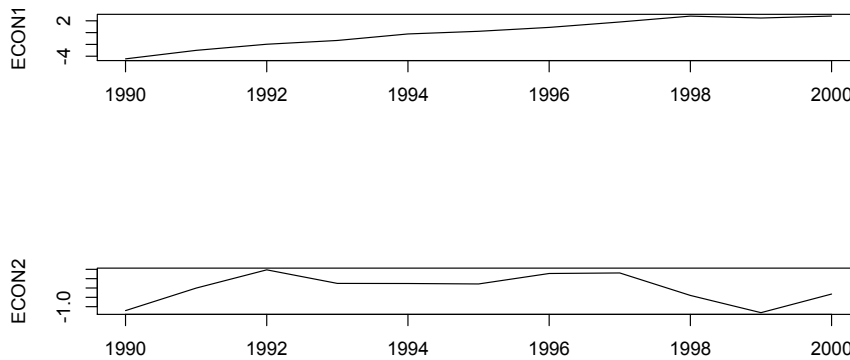

Figure 45: Venezuela Economic Index

J.2 Venezuela Globalization Index Check

Fraction of Variance Explained = 0.66 0.87 0.94

	TX.VAL.SERV.CD.WT	TM.VAL.SERV.CD.WT	IS.SHP.GOOD.TU	IC.EXP.COST.CD
[1,]	0.27797927	-0.26063780	0.28085034	-0.280514512
[2,]	0.09446163	0.18864238	0.01709721	-0.018252283
[3,]	0.02469745	0.08843422	0.01693855	0.001346709
	IC.IMP.COST.CD	GC.TAX.IMPT.CN	BN.CAB.XOKA.CD	DT.TDS.DPNG.CD
[1,]	-0.280420546	0.1596634	0.28047588	0.1690523
[2,]	-0.007432858	0.5204524	0.03888426	-0.1687943
[3,]	0.004992369	0.1290370	-0.01895533	0.5389221
	EG.IMP.CONS.ZS	TX.VAL.MRCH.XD.WD	TX.QTY.MRCH.XD.WD	NE.RSB.GNFS.CD
[1,]	0.24732391	0.25157257	0.27558783	0.1383127
[2,]	-0.19534632	0.21825294	-0.10154564	0.2378241
[3,]	0.08918916	0.03991784	-0.01688848	-0.7074606
	BX.KLT.DINV.CD.WD	PA.NUS.FCRF	IQ.WEF.PORT.XQ	TM.TAX.MRCH.SM.AR.ZS

[1,]	0.2234612	0.06185843	-0.27872892	-0.27860355
[2,]	-0.1735240	0.61099570	-0.08559907	0.06745268
[3,]	-0.3247262	0.24430500	-0.01229786	-0.04439594

GC.TAX.INTT.RV.ZS

[1,]	0.23926682
[2,]	-0.29320038
[3,]	0.07887191

	GLOB1	GLOB2	GLOB3
KOF	0.956327	-0.307337	-0.1361198

N = 53

J.3 VE Testing Model Assumptions

PROTEST MODEL

Coefficients:

(Intercept)	IMFP2	STHARD2
-9.445e-17	1.066e+00	3.278e-01

Shapiro-Wilk normality test

W = 0.9235, p-value = 0.349

Breusch-Godfrey test for serial correlation of order up to 1

data: PROT1 ~ IMFP2 + STHARD2

LM test = 0.8991, df = 1, p-value = 0.343

HARDSHIP MODEL

Coefficients:

(Intercept)	IMFP2	LTHARD2	NSI2	CIVLIB2
7.517e-16	4.873e-01	-3.046e-01	4.806e-01	7.400e-01
ECON2				
6.452e-01				

Shapiro-Wilk normality test

W = 0.9458, p-value = 0.5903

Breusch-Godfrey test for serial correlation of order up to 1

data: STHARD2 ~ IMFP2 + LTHARD2 + NSI2 + CIVLIB2 + ECON2

LM test = 0.6819, df = 1, p-value = 0.4089

J.4 VE Granger Causality Testing

```
Granger Test
          F-statistic    p-value
CIVLIB2 -> PROT2    7.298594381 0.03056857
CIVLIB2 -> IMFP2    7.847235829 0.02647506
ECON2 -> IMFP2      3.635653679 0.09822763
PROT2 -> LTHARD2    5.996396593 0.04418792
NSI2 -> LTHARD2     6.261390318 0.04085588
ECON2 -> CIVLIB2    4.458742239 0.07261951
ECON2 -> NSI2       3.682360926 0.09647902
```

```
max.lag = 1
```

J.5 VE Path Models

	PROT1	IMFP2	STHARD2	LTHARD2	CIVLIB2	ECON2
PROT1	1.00	0.46	0.16	0.31	0.33	0.67
IMFP2	0.46	1.00	0.04	-0.07	-0.62	0.03
STHARD2	0.16	0.04	1.00	-0.62	0.26	-0.13
LTHARD2	0.31	-0.07	-0.62	1.00	0.06	0.22
CIVLIB2	0.33	-0.62	0.26	0.06	1.00	0.51
ECON2	0.67	0.03	-0.13	0.22	0.51	1.00

FEEDFORWARD MODEL

AIC = 49.518

Parameter Estimates

	Estimate	Std Error	z value	Pr(> z)	
p41	-0.0028285	0.248819	-0.011368	9.9093e-01	STHARD2 <--- IMFP2
p42	-0.6237381	0.255031	-2.445731	1.4456e-02	STHARD2 <--- LTHARD2
p43	-0.0121758	0.254424	-0.047856	9.6183e-01	STHARD2 <--- ECON2
p54	0.2558163	0.305705	0.836807	4.0270e-01	CIVLIB2 <--- STHARD2
p56	-0.1637592	0.126254	-1.297064	1.9461e-01	PROT1 <--- STHARD2
p65	1.0784222	0.126140	8.549397	1.2373e-17	PROT1 <--- CIVLIB2
p61	1.1389210	0.122060	9.330802	1.0507e-20	PROT1 <--- IMFP2
E6	0.1487007	0.066501	2.236068	2.5347e-02	PROT1 <--> PROT1
E5	0.9345580	0.417947	2.236068	2.5347e-02	CIVLIB2 <--> CIVLIB2
E4	0.6144162	0.274775	2.236068	2.5347e-02	STHARD2 <--> STHARD2

Iterations = 0

FEEDBACK MODEL

AIC = 69.391

Parameter Estimates

	Estimate	Std Error	z value	Pr(> z)	
p41	-0.031606	0.28429	-0.11118	0.911476	IMFP2 <--- STHARD2
p42	-0.620836	0.24790	-2.50435	0.012268	LTHARD2 <--- STHARD2
p43	0.125778	0.31372	0.40093	0.688471	ECON2 <--- STHARD2
p54	0.227092	0.32238	0.70443	0.481165	STHARD2 <--- CIVLIB2

```

p56 0.087667 0.32238 0.27194 0.785669 STHARD2 <--- PROT1
p65 0.327653 0.29877 1.09667 0.272786 CIVLIB2 <--- PROT1
p61 0.465639 0.28429 1.63793 0.101436 IMFP2 <--- PROT1
E6 0.786952 0.35194 2.23607 0.025347 IMFP2 <--> IMFP2
E5 0.892643 0.39920 2.23607 0.025347 CIVLIB2 <--> CIVLIB2
E4 0.927698 0.41488 2.23607 0.025347 STHARD2 <--> STHARD2
E3 0.984180 0.44014 2.23607 0.025347 ECON2 <--> ECON2
E2 0.614562 0.27484 2.23607 0.025347 LTHARD2 <--> LTHARD2

```

Iterations = 0

SIMPLIFIED FEEDFORWARD MODEL

AIC = 35.01

Parameter Estimates

	Estimate	Std Error	z value	Pr(> z)	
p41	-0.0028285	0.248819	-0.011368	9.9093e-01	STHARD2 <--- IMFP2
p42	-0.6237381	0.255031	-2.445731	1.4456e-02	STHARD2 <--- LTHARD2
p43	-0.0121758	0.254424	-0.047856	9.6183e-01	STHARD2 <--- ECON2
p56	-0.1637592	0.122062	-1.341607	1.7972e-01	PROT1 <--- STHARD2
p65	1.0784222	0.155802	6.921767	4.4605e-12	PROT1 <--- CIVLIB2
p61	1.1389210	0.155875	7.306613	2.7396e-13	PROT1 <--- IMFP2
E6	0.1487007	0.066501	2.236068	2.5347e-02	PROT1 <--> PROT1
E4	0.6144162	0.274775	2.236068	2.5347e-02	STHARD2 <--> STHARD2

Iterations = 0

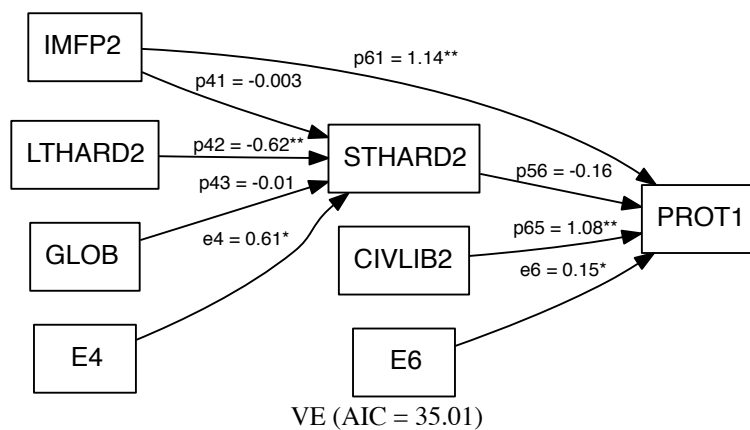

Figure 46: Venezuela Simplified Feedforward Path Model (* = $p \leq 0.05$, ** = $p \leq 0.01$)

MODIFIED FEEDFORWARD MODEL

AIC = 15.4

Parameter Estimates

	Estimate	Std Error	z value	Pr(> z)	
p41	-0.080518	0.307472	-0.26187	7.9342e-01	LTHARD2 <--- IMFP2
p43	-0.223285	0.307472	-0.72620	4.6772e-01	LTHARD2 <--- ECON2
p56	0.325760	0.082692	3.93946	8.1664e-05	PROT1 <--- LTHARD2
p65	0.993907	0.105358	9.43359	3.9628e-21	PROT1 <--- CIVLIB2
p61	1.103344	0.104232	10.58550	3.4792e-26	PROT1 <--- IMFP2
E6	0.066471	0.029727	2.23607	2.5347e-02	PROT1 <--> PROT1
E4	0.944660	0.422465	2.23607	2.5347e-02	LTHARD2 <--> LTHARD2

Iterations = 0

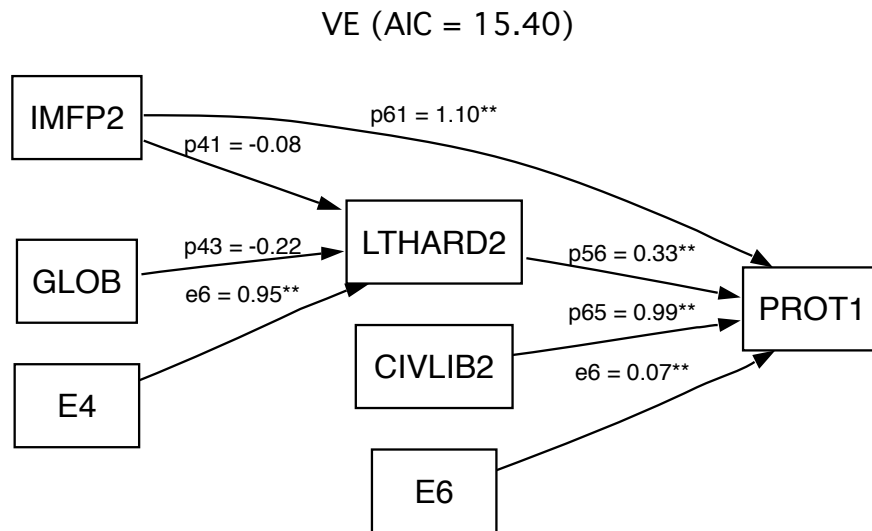

Figure 47: Venezuela Modified Feedforward Path Model (* = $p \leq 0.05$, ** = $p \leq 0.01$)

K Multimodel Averaging, Estimation and Testing

Multimodel averaging[1, 10] involves combining models to create generalized tests of theoretical constructs. Each Multimodel is constructed by averaging the correlation coefficients from different sets of countries. The overall Multimodel averaged correlation coefficients from Argentina + Brazil + Mexico + Venezuela. The next two Multimodels presented below averaged correlation coefficients from Argentina + Brazil and Mexico + Venezuela, respectively.

The results of the path modeling for each country (Argentina, Brazil, Mexico and Venezuela) suggest that two Multimodels, one for Argentina + Brazil and another for Mexico + Venezuela should be considered. The key difference between the two path models is the type of Hardships that generated protests. For Argentina + Brazil, STHARD is the primary intervening variable between world-system forces and PROT1. For Mexico + Venezuela, LTHARD is the primary intervening variable between world-system forces and PROT1.

K.1 Overall Multimodel

The correlation coefficients from the feed-forward (FF) models for Argentina, Brazil, Mexico and Venezuela were averaged to form a Multimodel correlation matrix. The simple FF model was then re-estimated using the Multimodel correlation matrix.

	PROT1	IMFP2	STHARD2	LTHARD2	CIVLIB2	ECON2
PROT1	1.00	0.30	0.50	0.35	0.04	0.40
IMFP2	0.30	1.00	0.35	-0.01	-0.17	-0.25
STHARD2	0.50	0.35	1.00	0.00	0.07	0.12
LTHARD2	0.35	-0.01	0.00	1.00	0.20	0.29
CIVLIB2	0.04	-0.17	0.07	0.20	1.00	0.40
ECON2	0.40	-0.25	0.12	0.29	0.40	1.00

AIC = 33.119

Parameter Estimates						
	Estimate	Std Error	z value	Pr(> z)		
p41	0.403833	0.14379	2.80846	4.9779e-03	STHARD2	<--- IMFP2
p42	-0.068025	0.14582	-0.46648	6.4087e-01	STHARD2	<--- LTHARD2
p43	0.239638	0.15045	1.59282	1.1120e-01	STHARD2	<--- ECON2
p56	0.440206	0.13942	3.15737	1.5920e-03	PROT1	<--- STHARD2
p65	0.040014	0.13277	0.30137	7.6313e-01	PROT1	<--- CIVLIB2
p61	0.157902	0.14148	1.11609	2.6438e-01	PROT1	<--- IMFP2
E6	0.731372	0.15773	4.63681	3.5383e-06	PROT1	<--> PROT1
E4	0.831505	0.17933	4.63681	3.5383e-06	STHARD2	<--> STHARD2

Iterations = 0

The results suggest that many of the effects that may or may not have been significant at the country level were significant when averaged together. Particularly the effect from STHARD2 -> PROT1 was significant, confirming the Shefner-Stewart model. The transmission paths from world-system total effects⁴ in the FF Multimodel are presented in Figure 48 page 62. The paths from IMF pressure through hardship to protest are significant and in the right direction. Effects from hardship and protest shocks are also significant.

⁴In path models, total effects are computed by multiplying coefficients along all the paths from exogenous to endogenous variables[49].

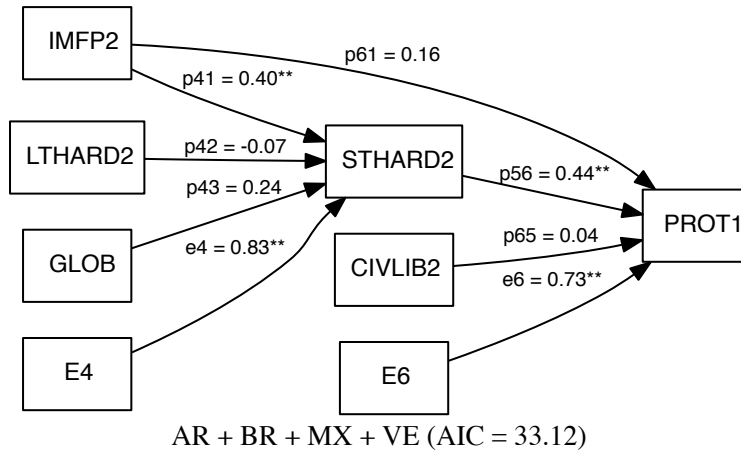

Figure 48: Simplified Multi Model Test (* = $p \leq 0.05$, ** = $p \leq 0.01$)

K.2 Argentina + Brazil

For Argentina and Brazil, the main paths to protest are through direct IMF pressure and through the effects of IMF pressure on short-term hardship.

	PROT1	IMFP2	STHARD2	LTHARD2	CIVLIB2	ECON2
PROT1	1.00	-0.06	0.57	0.31	-0.30	0.12
IMFP2	-0.06	1.00	0.44	-0.14	-0.07	-0.72
STHARD2	0.57	0.44	1.00	0.17	-0.37	-0.10
LTHARD2	0.31	-0.14	0.17	1.00	0.30	0.25
CIVLIB2	-0.30	-0.07	-0.37	0.30	1.00	0.23
ECON2	0.12	-0.72	-0.10	0.25	0.23	1.00

AIC = 27.362

Parameter Estimates						
	Estimate	Std Error	z value	Pr(> z)		
p41	0.755794	0.26029	2.90367	0.00368811	STHARD2 <---	IMFP2
p42	0.175022	0.18575	0.94225	0.34606397	STHARD2 <---	LTHARD2
p43	0.406729	0.26604	1.52883	0.12630737	STHARD2 <---	ECON2
p56	0.703455	0.18305	3.84299	0.00012154	PROT1 <---	STHARD2
p65	-0.070463	0.16499	-0.42707	0.66932751	PROT1 <---	CIVLIB2
p61	-0.375185	0.18275	-2.05304	0.04006824	PROT1 <---	IMFP2
E6	0.557729	0.17212	3.24037	0.00119375	PROT1 <-->	PROT1
E4	0.677978	0.20923	3.24037	0.00119375	STHARD2 <-->	STHARD2

Iterations = 0

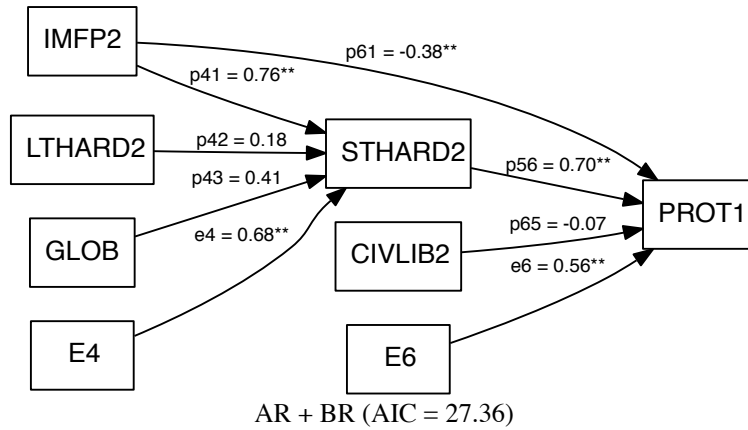

Figure 49: Argentina + Brazil, Simplified Multi Model Test (* = $p \leq 0.05$, ** = $p \leq 0.01$)

K.3 Mexico + Venezuela

For Mexico and Venezuela, the primary path to protest are through long-term hardship, IMF pressure and increases in civil liberties.

	PROT1	IMFP2	LTHARD2	CIVLIB2	ECON2
PROT1	1.00	0.67	0.39	0.39	0.67
IMFP2	0.67	1.00	0.11	-0.27	0.23
LTHARD2	0.39	0.11	1.00	0.09	0.34
CIVLIB2	0.39	-0.27	0.09	1.00	0.58
ECON2	0.67	0.23	0.34	0.58	1.00

AIC = 16.05

Parameter Estimates

	Estimate	Std Error	z value	Pr(> z)	
p41	0.037791	0.210516	0.17952	8.5753e-01	LTHARD2 <--- IMFP2
p43	0.333510	0.210516	1.58425	1.1314e-01	LTHARD2 <--- ECON2
p56	0.246783	0.085473	2.88727	3.8860e-03	PROT1 <--- LTHARD2
p65	0.582449	0.088147	6.60773	3.9025e-11	PROT1 <--- CIVLIB2
p61	0.796492	0.087242	9.12966	6.8712e-20	PROT1 <--- IMFP2
E6	0.143908	0.044411	3.24037	1.1937e-03	PROT1 <--> PROT1
E4	0.881553	0.272053	3.24037	1.1937e-03	LTHARD2 <--> LTHARD2

Iterations = 0

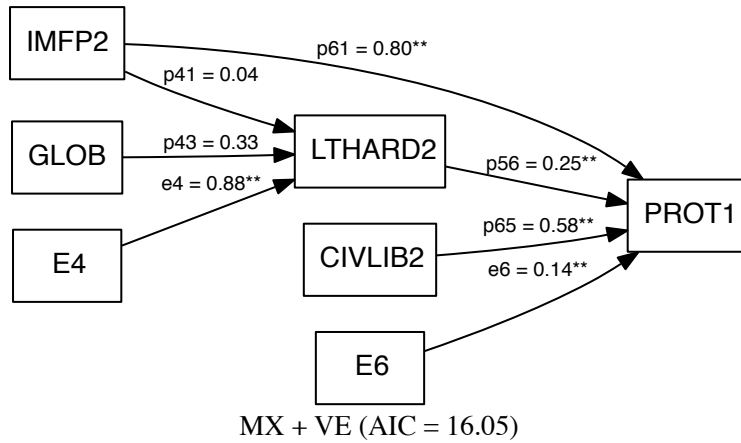

Figure 50: Mexico + Venezuela, Simplified Multi Model Test (* = $p \leq 0.05$, ** = $p \leq 0.01$)

Bibliography

- [1] Hirotugu Akaike. A New Look at the Statistical Model Identification. *IEEE Transactions on Automatic Control*, 19:716–723, December 1974.
- [2] R. G. D. Allen. *Macro-Economic Theory: A Mathematical Treatment*. St. Martin’s Press, New York, NY, 1968.
- [3] Salvatore J. Babones. The Country-Level Income Structure of the World-Economy. *Journal of World-Systems Research*, XI(1):29–55, July 2005.
- [4] Henrik P. Bang. David Easton’s Postmodern Images. *Political Theory*, 26(3):281–316, June 1998.
- [5] World Bank. World Development Indicators: Development Data & Statistics (<http://databank.worldbank.org/ddp/home.do>).
- [6] World Bank. International Debt Statistics. Web page, World Bank, <http://databank.worldbank.org/data/views/variableselection/selectvariables.aspx?source=international-debt-statistics>, 2014.
- [7] Edward B. Manoukian. *Modern Concepts and Theorems of Mathematical Statistics*. Springer-Verlag, New York, NY, 1986.
- [8] T. S. Breusch and A. R. Pagan. A Simple Test for Heteroscedasticity and Random Coefficient Variation. *Econometrica*, 47(5):1287–1294, Sep. 1979.
- [9] Kenneth P. Burnham and David R. Anderson. *Model selection and Multimodel Inference: A Practical Information-Theoretic Approach*. Springer-Verlag, New York, NY, 2nd edition, 2002.
- [10] Kenneth P. Burnham and David R. Anderson. Multimodel inference: understanding AIC and BIC in Model Selection. *Sociological Methods and Research*, 2004.

- [11] Stephane Champely. Power analysis functions along the lines of Cohen (1988). Technical Report <http://cran.r-project.org/web/packages/pwr/index.html>, R Foundation for Statistical Computing, 2012.
- [12] CIFP. Country Indicators for Foreign Policy. Web page, Carleton University, <http://www4.carleton.ca/cifp/>, 2014.
- [13] J. Cohen. *Statistical power analysis for the behavioral sciences*. Lawrence Erlbaum, Hillsdale, NJ, 2nd edition, 1988.
- [14] Barry Commoner. A Bulletin Dialogue: on "The Closing Circle" – Response. *Bulletin of the Atomic Scientists*, pages 17–56, May 1972.
- [15] A. P. Dempster, N. M. Laird, and D. B. Rubin. Maximum likelihood from incomplete data via the EM algorithm. *Journal of the Royal Statistical Society, Series B*, 39(1):1–38, 1977.
- [16] Axel Dreher. KOF Index of Globalization <http://globalization.kof.ethz.ch/>.
- [17] Axel Dreher. The Development and Implementation of IMF and World Bank Conditionality. HWWA Discussion Paper 165, Hamburg Institute of International Economics, 2002.
- [18] Axel Dreher. Does Globalization Affect Growth? Evidence from a new Index of Globalization. *Applied Economics*, 38(10):1091–1110, 2006.
- [19] Axel Dreher. IMF Conditionality: Theory and Evidence. KOF Working papers 08-188, KOF Swiss Economic Institute, ETH Zurich, February 2008.
- [20] Axel Dreher. *Measuring Globalization—Gauging its Consequences*. Springer, New York, NY, 2008.
- [21] Axel Dreher, Noel Gaston, Pim Martens, and Lotte Van Boxem. Measuring Globalization – Opening the Black Box. A Critical Analysis of Globalization Indices. *Journal of Globalization Studies*, 1(1):166–185, May 2010.
- [22] David Easton. An approach to the analysis of political systems. *World Politics*, 9(3):383–400, April 1957.
- [23] David Easton, editor. *A Systems Analysis of Political Life*. The University of Chicago Press, Chicago, IL, 1979.
- [24] Paul R. Ehrlich and John P. Holdren. Impact of population growth. *Science*, 171(3977):1212–1217, 1971.
- [25] W. Findeisen et al. *Control and Coordination in Hierarchical Systems*. John Wiley & Sons, New York, NY, 1980.
- [26] John Fox. Effect analysis in Structural Equation Models: Extensions and Simplified Methods of Computation. *Sociological Methods and Research*, 9(3):3–28, 1980.
- [27] John Fox. Structural Equation Modeling With the sem Package in R. *Structural Equation Modeling*, 12(2):465–486, 2006.
- [28] James E. Gentle, Yuichi Mori, and Waolana Hardle, editors. *Handbook of Computational Statistics: Concepts and Methods*. Springer-Verlag, Berlin, FRG, 2004.
- [29] C. W. J. Granger. Some properties of time series data and their use in econometric model specification. *Journal of Econometrics*, 16(1):121–130, 1981.
- [30] Jerald Hage. *Techniques and Problems of Theory Construction in Sociology*. John Wiley and Sons, New York, NY, 1972.

- [31] David R. Heise. *Causal Analysis*. John Wiley & Sons, New York, NY, 1975.
- [32] Freedom House. Freedom in the World. Technical report, Freedom House, <http://www.freedomhouse.org/report-types/freedom-world#.VBxcjUuUQ1g>, 1972–2014.
- [33] International IDEA. Databases and Networks. Web page, International Institute for Democracy and Electoral Assistance, <http://www.idea.int/resources/databases.cfm>, 2014.
- [34] IMF. IMF Survey Issues 2008. Web page, International Monetary Fund, <http://www.imf.org/external/pubs/ft/survey/surveyx.htm>, 2008.
- [35] IMF. Annual Report of the Executive Board. Web page, International Monetary Fund, <http://www.imf.org/external/pubs/ft/ar/>, 2014.
- [36] I. T. Jolliffe. *Principal Component Analysis*. Springer-Verlag, New York, NY, 1990.
- [37] Yoichi Kaya and Keiichi Yokobori, editors. *Environment, energy, and economy: Strategies for sustainability*. United Nations University Press, Shibuya-ku, Tokyo, 1997.
- [38] David A. Kenny. *Correlation and Causality*. John Wiley & Sons, New York, NY, 1979.
- [39] Niki Kitsantonis and Rachel Donadio. Greek Parliament Passes Austerity Plan After Riots Rage. *New York Times*, (http://www.nytimes.com/2012/02/13/world/europe/greeks-pessimistic-in-anti-austerity-protests.html?_r=1&nl=todaysheadlines&emc=th2), February 12, 2012.
- [40] Naomi Klein. *The Shock Doctrine: The Rise of Disaster Capitalism*. Picador, New York, NY, 2007.
- [41] Andrey V Korotayev and Sergey V. Tsirel. A spectral analysis of world gdp dynamics: Kondratieff waves, kuznets swings, juglar and kitchin cycles in global economic development, and the 2008–2009 economic crisis. *Structure and Dynamics*, 4(1), 2010.
- [42] LexisNexis. LexisNexis Academic. Web page, LexisNexis, <http://www.lexisnexis.com/en-us/products/lexisnexis-academic.page>, 2014.
- [43] Monty G. Marshall. Polity IV Project: Political Regime Characteristics and Transitions, 1800–2013. Web page, Polity IV Project, <http://www.systemicpeace.org/polity/polity4.htm>, 2014.
- [44] Donald F. Morrison. *Multivariate Statistical Methods*. McGraw-Hill, New York, NY, 1967.
- [45] Nebojsa Nakicenovic et al. IPCC Special Report on Emissions Scenarios. Special report, IPCC, 2000.
- [46] United Nations. Human Development Reports: Data. Web page, United Nations, <http://hdr.undp.org/en/data>, 2014.
- [47] Howard H. Patee, editor. *Hierarchy Theory: The Challenge of Complex Systems*. George Braziller, New York, NY, 1973.
- [48] Judea Pearl. *Causality: models, reasoning, and inference*. Cambridge University Press, New York, NY, 2000.
- [49] Elazar J. Pedhazur and Fred Nichols Kerlinger. *Multiple regression in behavioral research: explanation and prediction*. Holt, Rinehart and Winston, New York, NY, 1982.
- [50] Ilya Prigogine and Isabelle Stengers. *Order Out of Chaos: Man's New Dialogue with Nature*. Bantam Books, New York, NY, 1984.

- [51] R Development Core Team. R: A language and environment for statistical computing. Technical Report <http://www.R-project.org/>, R Foundation for Statistical Computing, Vienna, Austria, 2006.
- [52] James C. Scott. *The Moral Economy of the Peasant: Rebellion and Subsistence in Southeast Asia*. Yale University Press, New Haven, CT, 1976.
- [53] Thomas Richard Shannon. *An Introduction to the World-System Perspective*. Westview Press, Boulder, CO, 1989.
- [54] S. S. Shapiro and M. B. Wilk. An analysis of variance test for normality (complete samples). *Biometrika*, 52(3 and 4):591–611, 1965.
- [55] John Shefner, Cory Blad, and George Pasdirtz. Globalization and the World System. Website <https://www.dropbox.com/sh/gk830b626dd6nq9/AAC95FjylwM8vihA2rEab0Fna?dl=0>, University of Wisconsin–Madison, Madison, WI, USA, 2010.
- [56] Jon Shefner and Julie Stewart. Neoliberalism, Grievances and Democratization: An Exploration of the Role of Material Hardships in Shaping Mexico’s Democratic Transition. *Journal of World-Systems Research*, XVII(2):353–378, 2011.
- [57] Herbert A. Simon. The Organization of Complex Systems. In Howard H. Patee, editor, *Hierarchy Theory: The Challenge of Complex Systems*, pages 3–27. George Braziller, New York, NY, 1972.
- [58] N. J. Smith and A. P. Sage. An introduction to hierarchical systems theory. *Computers & Electrical Engineering*, 1(1):55–71, 6 1973.
- [59] Joseph E. Stiglitz. *Globalization and Its Discontents*. W. W. Norton, New York, NY, 2002.
- [60] Joseph E. Stiglitz. *Making Globalization Work*. W. W. Norton & Company, New York, NY, 2007.
- [61] Debra Straussfogel. A systems perspective on world-systems theory. *Journal of Geography*, 96(2):119–126, 2014/04/03 1997.
- [62] Kelley Strawn. Validity and Media-derived Protest Event Data: Examining Relative Coverage Tendencies in Mexican News Media. *Mobilization*, 13(2):147–164, 2008.
- [63] E. P. Thompson. The Moral Economy of the English Crowd in the 18th Century. *Past & Present*, 50:76–136, 1971.
- [64] Ludwig von Bertalanffy. *General System Theory: Foundations, Development, Applications*. George Braziller, New York, 1968.
- [65] P. E. Waggoner and J. H. Ausbel. A framework for sustainability science: A renovated IPAT identity. *PNAS*, 99(12):7860–7865, June 11, 2002.
- [66] Immanuel Wallerstein. Globalization or the Age of Transition? A Long-term View of the Trajectory of the World System. *International Sociology*, 15(2):251–267, June 2000.
- [67] Immanuel Wallerstein. *World-System Analysis: An Introduction*. Duke University Press, Durham, NC, 2004.
- [68] John Walton and Charles Ragin. Global and National Sources of Political Protest: Third World Responses to the Debt Crisis. *American Sociological Review*, 55(6):876–890, December 1990.